



## TYPE DVC5320

### Mechanical limit switch box

**TABLE OF CONTENTS**

1. Introduction	3
1.1 Purpose	3
1.2 Safety notice	3
2. Product identification	4
2.1 Marking	4
2.2 Initial inspection	4
2.3 Storage	4
3. General information	5
3.1 Type 5320 standard technical data	5
3.2 Type 5320 optional technical data	5
3.3 Internal parts / materials	5
3.4 Dimensions	6
4. Installation instructions	6
4.1 Pre-installation	6
4.2 Limit switch box mounting	6
4.3 Fitting the mounting bracket	7
4.4 Adjustment of the limit switch box	8
4.4.1 Open cam setting	8
4.4.2 Closed cam setting	8
4.4.3 Checking the switch cam setting	9
4.4.4 Wiring	9
4.4.5 Reassembly of limit switch box	9
5. Operation instructions	10
5.1 Electrical connections and preliminary test	10
5.2 Wiring	10
5.3 Operation	10
6. Maintenance	11
6.1 Maintenance	11

# 1. Introduction

## 1.1 Purpose

This installation and operating manual explains how to install, operate and maintain Type 5320 limit switch boxes.

## 1.2 Safety notice

Safety notices in his manual stating precautions the user must take to reduce the risk of personal injury and damage to the equipment. User must read these instructions before installation, operating or maintenance is carried out.



**DANGER:** Refers to personal safety. Alert the user of danger or harm. The hazard or unsafe practice will result in severe injury or death

---



**WARNING:** Refers to personal safety. Alert user of potential danger. Failure to follow warning notices could result in personal injury or death

---

---

**CAUTION:** Directs the user's attention to general precautions that, if not followed could result in personal injury and/or damage

---

## 2. Product identification

### 2.1 Marking

The limit switch box name plate is located on the top cover casing. The name plate contains the following:

- Logo
- Type number
- Enclosure
- Rated current
- Accreditations, certifications

### 2.2 Initial inspection

When you receive the limit switch box, please make sure that the specifications of the limit switch box (name plate) confirms with the customer order sheet and / or the required specifications.

- Remove the packing wrap or carton box carefully. Inspect the product for any physical damage that may have occurred during shipment or handling.
- Check the product specification with your order. If something does not match the requirements / differs from the expected, please contact us immediately for required actions to be carried out.

### 2.3 Storage

Limit switch boxes must be stored in a clean, cool and dry area. The unit shall be stored with cover installed and the conduit entries sealed. Storage must be off the floor, covered with a sealed dust protector.

If limit switch boxes are to be stored outside before use / installation they must be stored off the ground, high enough to prevent them from being immersed into water or covered with snow.

***The conduit entries shall remain sealed until mounting of the power cable / signal cable takes place.***

### 3. General information and features

The type DVC5320 limit switches are designed for the use in various types of industries together with small size valves i.e. butterfly valve, ball valves etc. for signaling / valve position monitoring purposes.

#### 3.1 Type 5320 standard technical data

Enclosure Rating:	Weatherproof IP67 & NEMA 4 & 4X
Enclosure:	High grade aluminum alloy
Ambient Temperature:	-20°C ~ + 80°C
Conduit Entries:	2x M20
Travel Angle:	90 degree +/- 10%
Position Indicator:	open: green, close: red
Switch Mechanical:	2 x SPDT - Rating: 250VAC/16A, 125VAC/16A, 250VDC/0,3A, 125VDC/0,6A, 30VDC/10A
Terminal strip:	8 point
External coating:	Chromate polyester powder coating

#### 3.2 Type 5320 optional technical data

Enclosure rating:	IP68
Enclosure:	High grade aluminum alloy
Conduit entries:	2x PF 1/2", PT 1/2", NPT 1/2", PG 13,5
Switches:	Proximity switches
Indication:	Three way dome indication

#### 3.3 Internal parts/materials

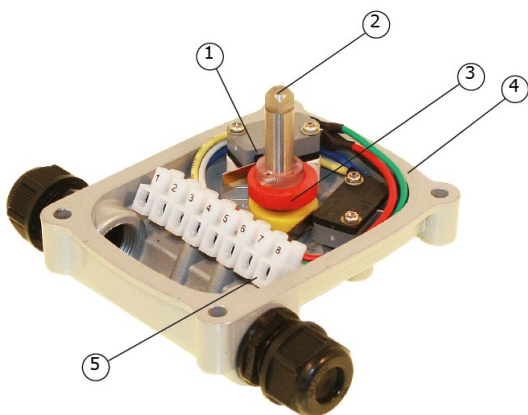

NO.	DESCRIPTION	MATERIAL
1	SWITCH	2-SPDT
2	AXLE	STAINLESS STEEL
3	CAM	POLYCARBONATE
4	BODY	ALUMINUM DIE-CAST
5	TERMINAL STRIPS	POLYCARBONATE

#### 3.4 Dimensions

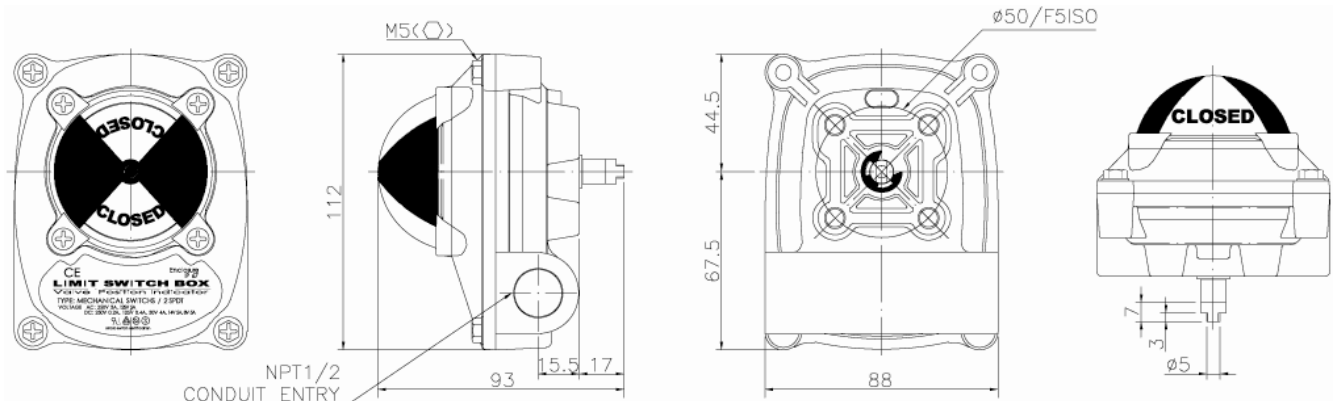

## 4. Installation instructions

### 4.1 Pre-installation

Verify that the nameplate of the limit switch box match the specifications needed – correct model number, voltage and enclosure type - before installation and use.

- Wiring connections should be in accordance with the diagram attached to the inside of the top casing cover.
- The two conduit cable entries shall be sealed in a proper manner until cable works is finalized.
- Position indicator and switch box covers are sealed by use of o-rings. Please take care of o-ring in order not to cause any damage to the o-rings during disassembly or reassembly.
- The position of the limit switches / cams have not been adjusted at the factory. Therefore a final adjustment of those is needed before use.
- **Do not use in areas where explosion proof equipment is required.** These types of limit switches are designed as weatherproof types – not explosion proof types.

### 4.2 Limit switch box mounting

**Note:**

- Prior to mounting of the limit switch box the item must be checked for any damage
- Damaged parts must be replaced by original spare parts

Mounting is most easily done with the actuator shaft pointing vertically upwards. But mounting is also possible in any other position.

The limit switch box may be mounted in any position.

It is mandatory that the limit switch box is firmly secured to a sturdy mounting bracket. High tensile bolts or studs with spring locking washers must be used.

The limit switch box output shaft must be in line with the actuator shaft to avoid side-loading the shaft. To avoid any backlash no flexibility in the mounting bracket or mounting should be allowed.

**Caution: Make sure to cut off the electrical power before working on the limit switch box for assembly, mounting etc.**

#### 4.3 Fitting the mounting bracket

Two types of standard mounting brackets are available

- NAMUR VDE/VDI 3845 size 30x80
- NAMUR VDE/VDI 3845 size 30x130

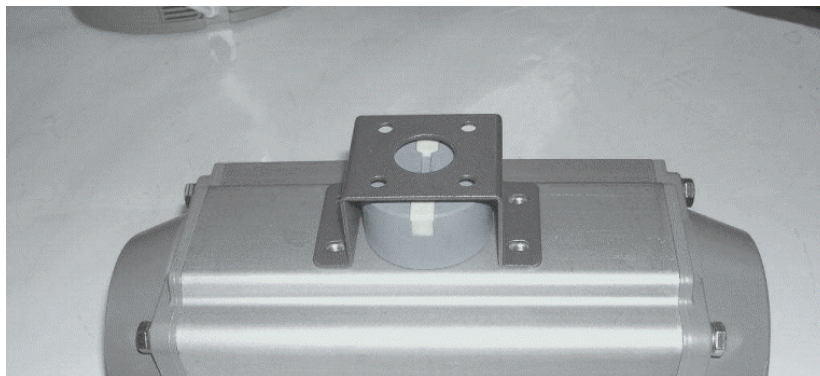

Fixed mounting bracket on top of actuator

The mounting bracket is fixed onto the top of the actuator by use of correctly sized high tensile bolts and spring washers.

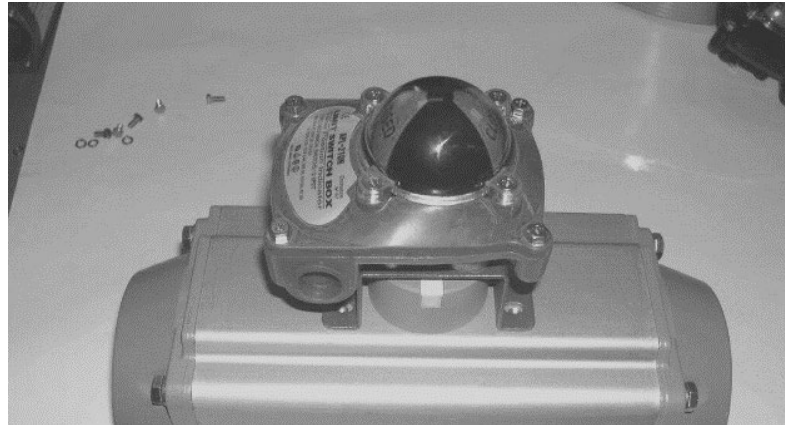

Insert the shaft of the limit switch box correctly into the drive slot on the top of the actuator drive shaft – use correctly sized high tensile bolts and spring washers for fastening the box to the bracket.

#### 4.4 Adjustment of the limit switch box

By use of screw driver loosen the captive bolt on the cover and lift off top cover.

Each switch has its own independent cam arrangement. Follow the procedures bellow for adjustment.

##### 4.4.1 Open cam setting

Lift the bottom cam up and turn it until the switch is activated (clicks) – then release the cam. The spring will force the cam back into the splines on the shaft ensuring the correct position of the cam.

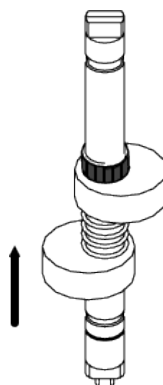

Lift up and release



#### 4.4.2 Closed cam setting

Push the top cam down and turn it until the switch is activated (clicks) – then release the cam. The spring will force the cam back into the splines on the shaft ensuring the correct position of the cam.

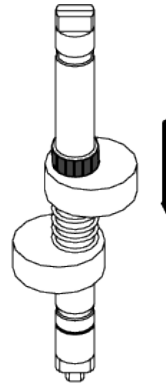

Push down and release

**NOTE:** It should be kept in mind that an incorrect setting of the cam position may/will result in incorrect signaling to external control systems.

#### 4.4.3 Checking the switch cam setting

Operate the actuator from full open to full closed in both directions several times to check that the switch cams are operating correctly – preferably with a detection of the output signal from the limit switches (if possible)

#### 4.4.4 Wiring

The correct wiring diagram is attached onto the inside of the top casing cover. Please follow the instructions carefully. If in doubt – please contact us.

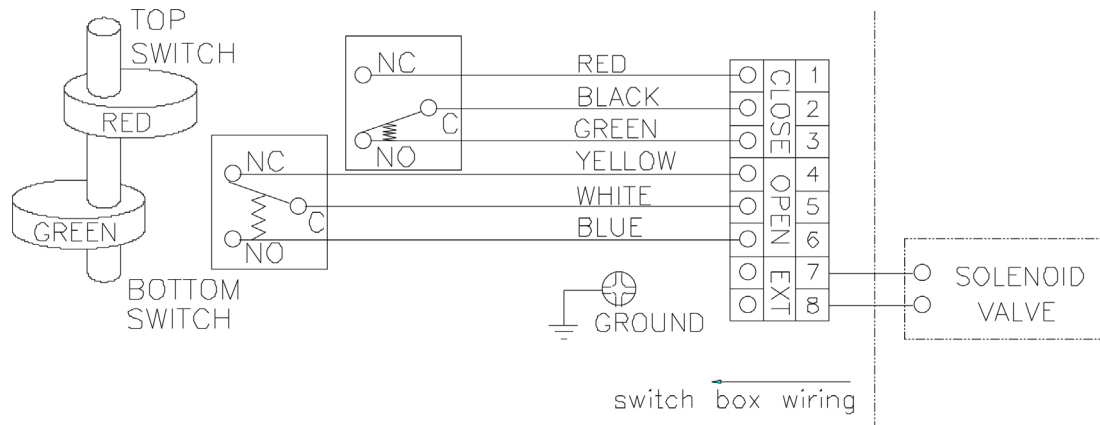

Standard electrical diagram

**Important: Earth wire cable shall be use in bicolor combination green/yellow**

#### 4.4.5 Reassembly of limit switch box

Carefully mount the top cover onto the bottom part of the casing – taking care not to damage the o-ring.

## 5. Operation instructions

### 5.1 Electrical connections and preliminary test



**WARNING:**

- ✓ Work on the electrical system or equipment must only be carried out by a skilled electrician himself or by specially instructed personnel under the control and supervision of such an electrician and in accordance with the applicable electrical engineering rules
- ✓ Cable gland or conduit entries shall be controlled by qualified engineers to ensure correct protection against water damages etc.
- ✓ Treat limit switch casing top with care. Gap between limit switch box housing parts may lead to unexpected damages. Do not jam cover during fitting.

### 5.2 Wiring

Please refer to the enclosed wiring diagram or contact us for further details.  
If the enclosed diagram is not followed/neglected – the guarantee will no longer be valid.

### 5.3 Operation

As to the fact that the limit switch are fully controlled/operated by the actuator shaft no manual operation is necessary.

## 6. Maintenance

### 6.1 Maintenance

**Caution:**

**Turn off all power services before attempting to perform service on the limit switch box. Before removing or disassembling the limit switch box ensure that the valve or other actuated device is isolated and not under pressure.**

**When/if replacing any part use only original spare parts.**

All though no real maintenance is necessary on the limit switch box, regular maintenance checks should, under normal conditions, be carried out with intervals of maximum six months. But if service conditions are severe more frequent inspections may be advisable.

- ✓ Ensure limit switch box / actuator alignment
- ✓ Ensure wiring insulation is intact, connected and terminated properly
- ✓ Ensure all screws are present and tight
- ✓ Ensure cleanliness of internal electrical parts / devices
- ✓ Ensure conduits connections are installed properly and dry
- ✓ Check enclosure o-ring seals and verify that the o-ring is not pinched between flange
- ✓ Visual inspect during open/close cycle
- ✓ Inspect identification labels for wear and replace if necessary

**WARNING:**

Before starting work on the limit switch box, please check all conditions of the limit switch box, other related equipment and site for safety purposes.