

PNEUMATIC ACTUATOR

TYPE DVC5051: (AIR/SPRING), DOUBLE ADJUSTABLE

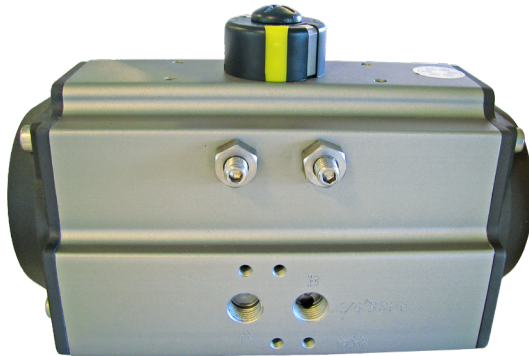

armatec



GENERAL

TORQUE:	14 TO 1620 NM AT 6 BAR
ROTATION ANGLE:	0° TO 90°. ADJUSTABLE +5° TO -5°
PRESSURE:	2 TO 10 BAR
TEMPERATURE:	-20° C TO +80° C
WORK MEDIA:	AIR (PNEUROP/ISO CLASS 4)
CONNECTIONS:	ISO 5211 FOR BRACKETS DIN 3337 COUPLING (STAR SHAPED) VDI/VDE 3845 FOR ACCESSORIES NAMUR FOR WORK MEDIA
AIR SUPPLY:	1/4" - BSPP (1/2" BSPP FOR SIZE 270)
SURFACE MATERIAL:	HARD ANODISED - 40µ

OPTIONS

ROTATION ANGLE:	120° AND 180°
MATERIAL:	BODY IN STAINLESS STEEL
TEMPERATURE:	-20° C TO +150° C (FPM) TYPE 5053 -40° C TO +80° C (LNBR)
END CAP:	0 - 45° ADJUSTMENT OF OPENING

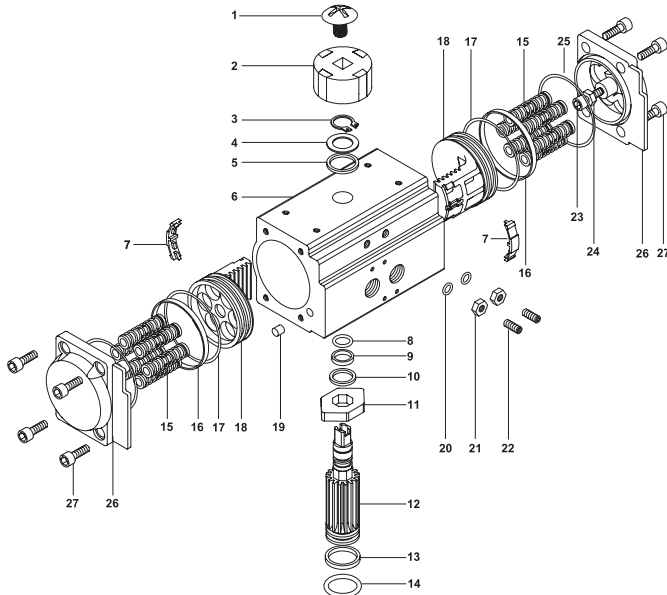

POS	DESCRIPTION	MATERIAL
1	INDICATOR SCREW	PLASTIC
2	INDICATOR	PLASTIC / STAINLESS STEEL
3	SPRING CLIP	STAINLESS STEEL (AISI 304)
4	METAL WASHER	STAINLESS STEEL (AISI 304)
5	OUTSIDE WASHER	ENGINEERING PLASTICS
6	BODY	EXTRUDED ALUMINIUM ALLOY 40µ
7	PLATE (PISTON)	ENGINEERING PLASTICS
8	INSIDE WASHER	ENGINEERING PLASTICS
9	O-RING (PINION TOP)	NBR
10	BEARING (PINION TOP)	ENGINEERING PLASTICS
11	TRAVEL STOP	ALLOY STEEL
12	PINION	ALLOY STEEL
13	O-RING (PINION BOT.)	ENGINEERING PLASTICS
14	BEARING (PINION BOT.)	NBR
15	SPRING	SPRING STEEL
16	BEARING (PISTON)	ENGINEERING PLASTICS
17	O-RING (PISTON)	NBR
18	PISTON	ALUMINIUM CASTING (101A)
19	HOLE SEALANT	NBR
20	O-RING (ADJUST. SCREW)	NBR
21	NUT (ADJUST. SCREW)	STAINLESS STEEL (AISI 304)
22	ADJUSTMENT SCREW	STAINLESS STEEL (AISI 304)
23	STOP SCREW	STAINLESS STEEL (AISI 304)
24	NUT (STOP SCREW)	STAINLESS STEEL (AISI 304)
25	O-RING (END CAP)	NBR
26	END CAP	ALUMINIUM CASTING (ADC12)
27	CAP SCREW	STAINLESS STEEL (AISI 304)

DESCRIPTION

- **Quality product** - based on modern technology and experience. Very long service.
- **Body in corrosion resistant, hard anodised aluminium** - 40µ
- **Nickle plated pinion and stainless steel screws** provide maximum protection against corrosion.
- **Serial number** for easy identification and traceability.
- **Excellent protection against wear** with high quality bearings at all moving parts.
- **Double adjustable** at 0° and 90° degrees . Perfect for quick and accurate adjustment especially for butterfly valves and 3-way ball valves.
- **Preloaded springs** with corrosion resistant epoxy coating enable an uncomplicated maintenance of the actuator.
- **Various actuator sizes** provide every possibility for perfect dimensioning.
- **100 % quality control** with function test and leakage test of all actuators.

DS-DVC5051-UK-01-2025-REV. D
We reserve the right for changes.

DIMENSIONS

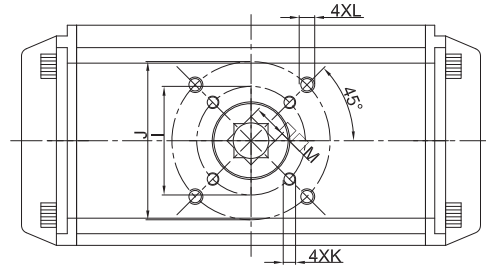
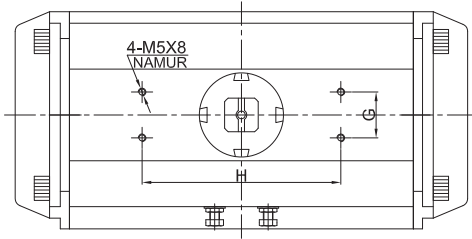
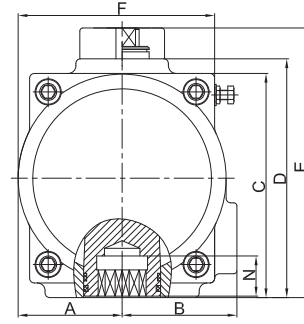
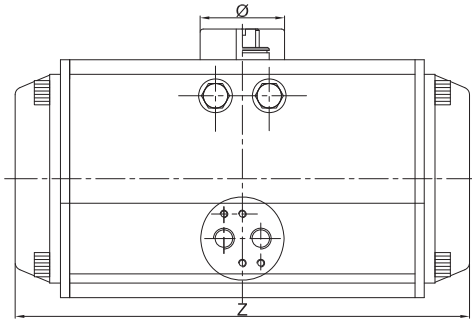

Size	A [MM]	B [MM]	C [MM]	D [MM]	E [MM]	F [MM]	G [MM]	H [MM]	ISO I	ISO J	K [MM]	L [MM]	M [MM]	N [MM]	Z [MM]	Ø [MM]
52	30.0	42.0	66.0	72.0	92.0	65.0	30	80	42 / F04	-	M5 x 8	-	9	14	145	40
52	30.0	42.0	66.0	72.0	92.0	65.0	30	80	36 / F03	50 / F05	M5 x 8	M6 x 10	11	14	145	40
63	36.0	47.0	81.0	88.0	108.0	72.0	30	80	36 / F03	50 / F05	M6 x 10	M8 x 13	11	14	166	40
63	36.0	47.0	81.0	88.0	108.0	72.0	30	80	42 / F04	-	M6 x 10	M8 x 13	11	14	166	40
63	36.0	47.0	81.0	88.0	108.0	72.0	30	80	50 / F05	70 / F07	M6 x 10	M8 x 13	14	18	166	40
75	42.0	53.0	94.0	100.0	120.0	81.0	30	80	36 / F03	50 / F05	M6 x 10	M8 x 13	11 / 14	14 / 18	180	40
83	46.0	57.0	99.0	109.0	129.0	92.0	30	80	50 / F05	70 / F07	M6 x 10	M8 x 13	14	18	205	40
92	50.0	59.0	111.0	117.0	137.0	98.0	30	80	50 / F05	70 / F07	M6 x 10	M8 x 13	14 / 17	18 / 21	258	40
105	58.0	64.0	123.0	133.0	153.0	110.0	30	80	70 / F07	102 / F10	M8 x 13	M10 x 16	17	21	270	40
125	68.0	75.0	146.0	155.0	175.0	128.0	30	80	70 / F07	102 / F10	M8 x 13	M10 x 16	22	26	302	55
140	75.0	77.0	161.0	172.0	192.0	138.0	30	80	102 / F10	125 / F12	M10 x 16	M12 x 20	22	26	394	55
160	87.0	87.0	184.0	197.0	217.0	158.0	30	80	102 / F10	125 / F12	M10 x 16	M12 x 20	22 / 27	26 / 31	451	55
190	103.0	103.0	216.0	230.0	260.0	189.0	30	130	125 / F12	-	M12 x 20	-	27	31	522	80
210	113.0	113.0	236.0	255.0	285.0	210.0	30	130	125 / F12	-	M12 x 20	-	27	31	527	80
240	130.0	130.0	265.0	289.0	319.0	245.0	30	130	140 / F14	-	M16 x 25	-	36	40	598	80
270	147.0	147.0	299.0	326.0	356.0	273.0	30	130	165 / F16	-	M20 x 25	-	46	50	720	80

Other ISO measures and larger dimensions on request.

ACTUATOR DATA

SIZE	SPRING RETURN (AIR/SPRING)										AIR [Ltr]	
	TORQUE [Nm]								WEIGHT [Kg]	OPEN (NC)		
	SPRING		PRESSURE 5 BAR		PRESSURE 6 BAR		PRESSURE 7 BAR					
0°	90°	0°	90°	0°	90°	0°	90°	0°	90°			
52	10.2	14.8	9.7	4.2	13.8	9.1	17.8	12.2	1.5	0.12	0.16	
63	16.4	25.0	20.0	11.4	27.3	18.6	34.6	25.9	2.2	0.21	0.23	
75	25.3	34.7	24.9	15.4	34.9	25.4	44.9	35.4	2.9	0.30	0.34	
83	38.0	55.2	40.4	23.2	56.1	38.9	71.7	54.5	3.6	0.43	0.47	
92	56.0	82.5	56.8	30.4	79.4	53.0	101.9	75.5	5.5	0.64	0.73	
105	75.9	118.1	89.4	47.5	122.5	80.6	155.5	113.6	6.7	0.95	0.88	
125	125.8	188.3	125.3	63.4	176.2	113.4	226.2	163.8	10.4	1.60	1.40	
140	206.0	310.5	221.8	118.5	307.8	203.8	392.1	289.5	14.4	2.50	2.20	
160	335.7	500.4	330.6	165.6	463.2	298.4	596.3	431.1	23.3	3.70	3.20	
190	480.1	742.4	584.2	322.7	797.5	535.1	1010.4	748.6	46.1	5.90	5.40	
210	660.3	912.1	670.3	418.5	936.9	684.2	1202.1	950.3	53.2	7.50	7.50	
240	985.2	1330.8	939.4	594.1	1323.4	979.6	1708.9	1363.4	73.3	11.00	9.00	
270	1342.4	1887.2	1582.4	1037.7	2167.2	1623.6	2751.3	2207.4	115.9	17.00	14.00	

Torque calculated from 12 springs.

Torques at different air pressures and spring sets than the above can be informed.