

# CHECK VALVE WITH SOFT SEALING

## TYPE 6140



### GENERAL

DIMENSION:	DN 40 - DN 300
PRESSURE:	PN 10/PN 16
MATERIAL:	ZINC PLATED STEEL C22.8 ACID-PROOF STAINLESS STEEL 1.4408
SEAT/TEMPERATURE:	NBR: -10°C TO +80 °C EPDM: -20°C TO +110 °C FPM: -20°C TO +170 °C
FLANGE O-RING:	SAME AS SEAT
FLANGE CONNECTION:	PN 10/PN 16

### OPTIONS

DIMENSION:	DN 350 - DN 600
PRESSURE:	PN 40
MATERIAL:	ALU-BRONZE
FLANGES:	GROOVES IN BEARING SURFACE
FLANGE CONNECTION:	PN 6 / PN 40

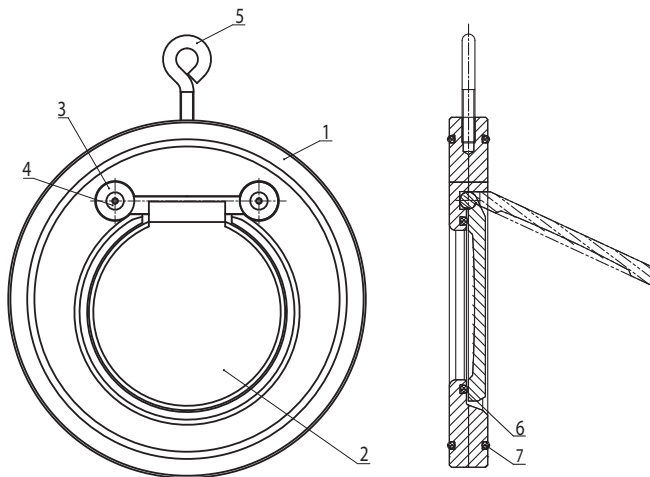

POS	DESCRIPTION	STEEL	STAINLESS STEEL
1	BODY	ZINC PLATED 1.0460	1.4408
2	DISC	ZINC PLATED 1.0619	1.4408
3	WASHER	ZINC PLATED	AISI 304
4	SCREW	ZINC PLATED	AISI 304
5	EYE BOLT	ZINC PLATED	AISI 304
4	SEAT O-RING	EPDM	EPDM/NBR/FPM
5	FLANGE O-RING	EPDM	EPDM/NBR/FPM

### DESCRIPTION

- **Very reliable** and simple construction.
- **Self aligning** between flanges.
- **Very flexible and low weight.**
- **Disc and hinge cast as one.**
- **Easy mounting** because of the eye bolt on top of the valve.
- **Large field of application** due to many options.
- **Protected o-ring.** The O-ring is placed in the body protecting it from flow, detachment and tear.
- **Can on demand be delivered with material certificate EN10204 - 3.1.**

**DIMENSION**

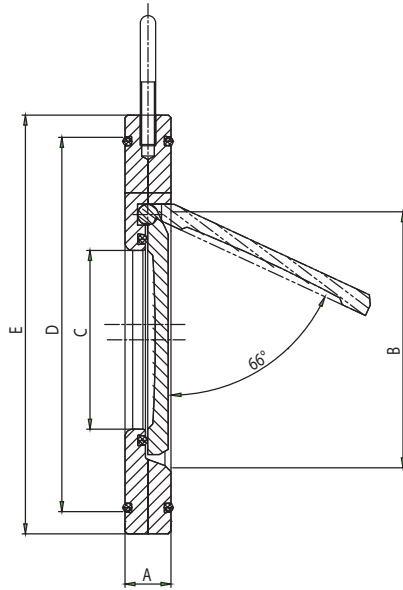

DIM [MM]	A [MM]	B [MM]	C [MM]	D [MM]	E [MM] PN 16	E [MM] PN 25	WEIGHT [KG]	KV-VALUE [M³/H]
40	16	43	22	72	95	95	0.8	17.2
50	14	54	32	86	109	109	0.9	25.4
65	14	70	40	109	129	129	1.3	42.1
80	14	82	54	119	144	144	1.5	67.1
100	18	106	70	146	164	164	2.4	245.9
125	18	132	92	173	195	195	3.3	546.1
150	20	159	112	197	220	220	4.8	722.4
200	22	207	154	255	275	275	7.8	1036.3
250	26	260	192	312	330	330	13.1	1892.0
300	32	309	227	363	380	387	22.0	2201.6

**PRESSURE DROP GRAPH**

TEST CONDITIONS:

MEDIA: WATER (H2O)  
WEIGHT: 1 KG/DM<sup>3</sup>  
TEMPERATURE: 15 °C.

Pressure Drop "ΔP" (BAR)

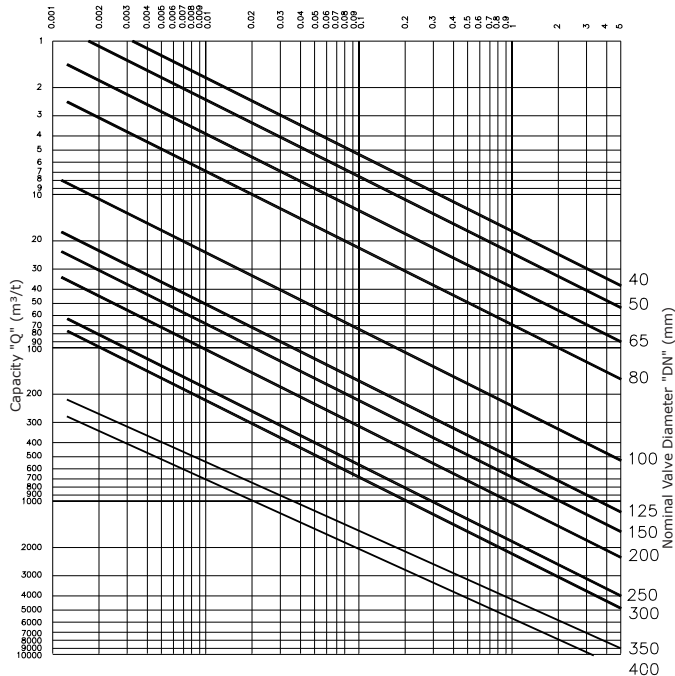

**OPENING PRESSURE**

DIM [MM]	OPENING PRESSURE [mbar]			
	FLOW DIRECTION			
	→	→	→	↑
	10° OPEN	30° OPEN	66° OPEN	UPWARD OPEN
40 - 150	3	9	13	16
200 - 400	3	12	19	22

The curves shown on the diagram represent pressure drop related to water at 15° C. Pressure drop related to fluids other than water (air or gas) is obtained by calculating the equivalent related water flow (Qe) and including this new value on the diagram.

To obtain the value of the equivalent water flow (Qe) the following formula should be applied:

$$Q_e = \sqrt{\frac{Y}{1000} \times Q}$$

Qe = Equivalent water flow in m³/h.  
Q = Fluid flow (air or gas) at operating conditions in m³/h.  
Y = Fluid density measured in operation conditions in kg/m³.

The pressure drops shown on the diagram and those obtained from the formula refer to valves fitted on horizontal pipelines. The valves indicated on the diagram are also applicable to valves fitted on vertical pipelines, only in case of partial valve opening. The resulting differences are unimportant.