

SANITARY 3-PCS BUTTERFLY VALVE

TYPE DVC2610

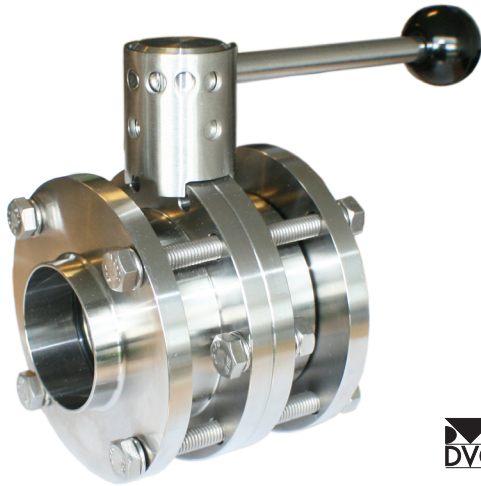

armatec



GENERAL

DIMENSION:	DN25 - DN104 (DIN 11850) DN20, DN40 - DN100 (SMS 3008)
PRESSURE:	10 BAR
TEMPERATURE:	-10°C TO 120°C
OPERATION:	4 POSITIONING HANDLE
CONNECTION:	BUTT WELD DIN 11850-SERIE 2 OR SMS 3008
SURFACE ROUGHNESS:	INSIDE <0.8 µm OUTSIDE <1.6 µm

OPTIONS

OPERATION:	ACTUATOR TYPE 505 OR STAINLESS STEEL CYLINDER TYPE 5126
SURFACE ROUGHNESS:	ELECTRICAL POLISHING RA <0,5 µm
FEEDBACK:	INDUCTIVE, MECHANICAL
LINER:	SILICONE, FPM

MATERIALS

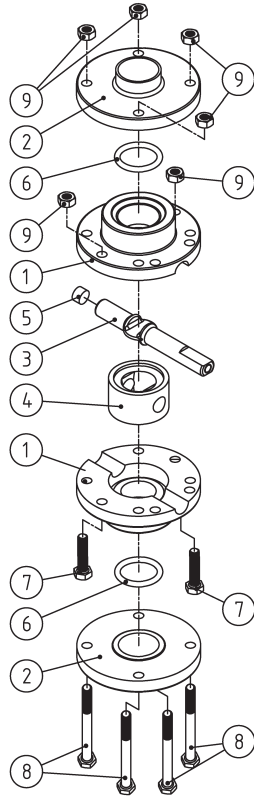
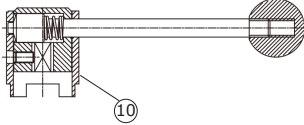

POS	BESKRIVELSE	MATERIALE
1	BODY	STAINLESS STEEL AISI 316L
2	END CAP	STAINLESS STEEL AISI 316L
3	DISC AND STEM	STAINLESS STEEL AISI 316L
4	SEAT	RUBBER EPDM
5	COVER	RUBBER EPDM
6	O-RING	RUBBER EPDM
7	BOLT	STAINLESS STEEL AISI 304
8	BOLT	STAINLESS STEEL AISI 304
9	NUT	STAINLESS STEEL AISI 304
10	HANDLE	STAINLESS STEEL AISI 304

DESCRIPTION

- **Sanitary 3-pcs butterfly valve** in very high quality, designed for usage in the food industry.
- **EC1935 and FDA food grade approvals** are standard and 3.1 material certificate is delivered on request.
- **Easy replaceable rubber liner**, because the middle part of the valve can be removed.
- **Weld ends according to SMS 3008 or DIN 11850** are standard.
- **The butterfly valve can be delivered with 4 positioning handle for manual operation or pneumatic actuator** with feedback signals for remote operation. Both solutions are elegant as well as cleaning-friendly.
- **Highly polished stainless steel** surface on both inside and outside makes the valve easily cleanable, and the 2-piece body design simplifies maintenance tasks.

DIMENSIONS

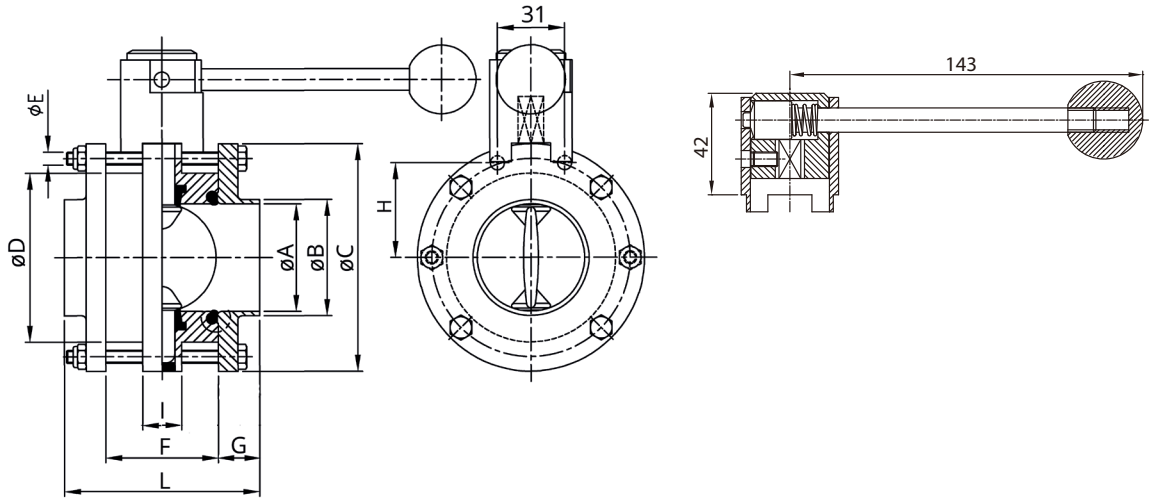

DIN 11850 butt weld ends											
DIM	ϕB	Wall thickness	ϕA	ϕC	ϕD	ϕE	F	G	H	I	L
	[MM]										
DN25	29.0	1.5	26.0	79.0	51.9	M8	50.0	20.0	30.6	18.0	90.0
DN32	35.0	1.5	32.0	85.0	60.0	M8	50.0	20.0	33.9	18.0	90.0
DN40	41.0	1.5	38.0	90.0	65.0	M8	60.0	20.0	36.0	18.0	100.0
DN50	53.0	1.5	50.0	105.0	78.0	M8	60.0	20.0	43.7	18.0	100.0
DN65	70.0	2.0	66.0	125.0	98.0	M8	60.0	20.0	53.8	18.0	100.0
DN80	85.0	2.0	81.0	137.0	110.0	M8	76.0	30.0	59.8	21.0	136.0
DN100	104.0	2.0	100.0	157.0	130.0	M8	76.0	30.0	69.4	21.0	136.0

SMS 3008 svejseender											
DIM	ϕB	Wall thickness	ϕA	ϕC	ϕD	ϕE	F	G	H	I	L
	[MM]										
DN20	25.0	1.20	22.6	79.0	51.9	M8	50.0	20.0	30.6	18,0	90.0
DN40	38.0	1.20	35.6	85.0	60.0	M8	50.0	20.0	33.9	18,0	90.0
DN50	51.0	1.20	48.6	105.0	78.0	M8	60.0	20.0	43.7	18,0	100.0
DN65	63.5	1.60	60.3	112.0	85.0	M8	60.0	20.0	47.0	18,0	100.0
DN80	76.1	1.60	72.9	125.0	98.0	M8	60.0	20.0	53.8	18,0	100.0
DN100	101.6	2.00	97.6	157.0	130.0	M8	76.0	30.0	69.4	21,0	136.0

VALVE DATA

DIM [MM]	MAX. TORQUE [NM]	WEIGHT FREE STEM [KG]
DN20	13	2.30
DN25	13	2.36
DN32	13	2.44
DN40	13	2.56
DN50	16	2.64
DN65	18	3.32
DN80	23	3.88
DN100	34	6.00

Excl. safety factor

PRESSURE / TEMPERATURE

Working pressure:

- -0.9 bar~10 bar

Working temperature:

- Silicon: -20°C~210°C
- EPDM: -10°C~120°C
- Viton: -10°C~210°C