

# SANITARY 2-PCS BUTTERFLY VALVE

## TYPE DVC2600



armatec



### GENERAL

DIMENSION:	DN25 - DN150 (DIN 11850) DN20, DN40 - DN100 (SMS 3008)
PRESSURE:	10 BAR
TEMPERATURE:	-10°C TO 120°C
OPERATION:	4 POSITIONING HANDLE
CONNECTION:	BUTT WELD DIN 11850-SERIE 2 OR SMS 3008
SURFACE ROUGHNESS:	INSIDE <0.8 µm OUTSIDE <1.6 µm

### OPTIONS

DIMENSION:	DN150 (SMS 3008)
OPERATION:	ACTUATOR TYPE 505 OR STAINLESS STEEL CYLINDER TYPE 5126
SURFACE ROUGHNESS:	ELECTRICAL POLISHING
FEEDBACK:	INDUCTIVE, MECHANICAL
LINER:	SILICONE, FPM

### MATERIALS

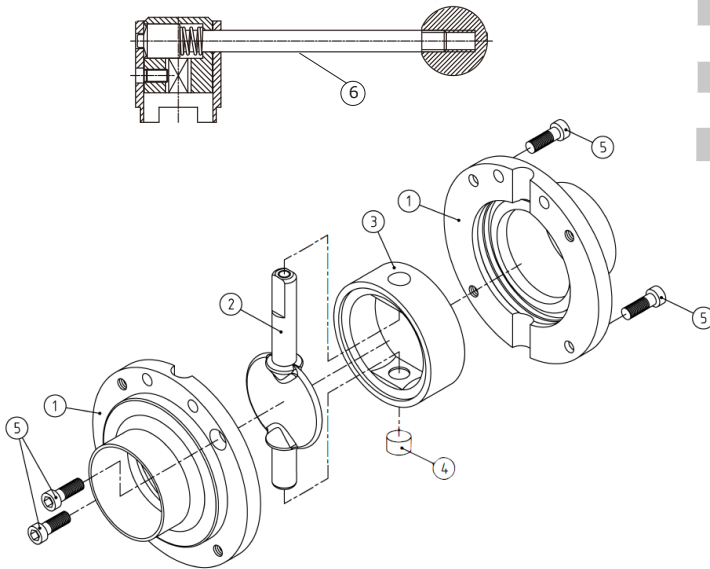

POS	DESCRIPTION	MATERIAL
1	BODY	STAINLESS STEEL AISI 316L
2	DISC AND STEM	STAINLESS STEEL AISI 316L
3	LINER	EPDM
4	COVER	EPDM
5	SCREW BOLTS	STAINLESS STEEL AISI 304
6	HANDLE	STAINLESS STEEL AISI 304

### DESCRIPTION

- **Sanitary butterfly valve** in very high quality, designed for usage in the food industry.
- **EC1935 and FDA food grade approvals** are standard and 3.1 material certificate is delivered on request.
- **Easy replaceable rubber liner.** See a video how to replace the liner on our website [www.dvc.nu/videos](http://www.dvc.nu/videos).
- **Weld ends according to SMS 3008 or DIN 11850** are standard.
- **The butterfly valve can be delivered with 4 positioning handle for manual operation or pneumatic actuator** with feedback signals for remote operation. Both solutions are elegant as well as cleaning-friendly.
- **Highly polished stainless steel** surface on both inside and outside makes the valve easily cleanable, and the 2-piece body design simplifies maintenance tasks.

## DIMENSIONS

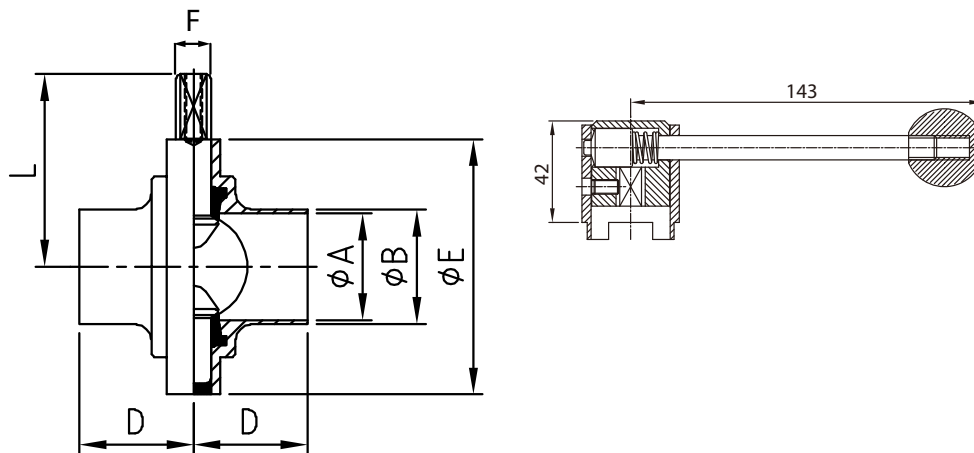

### DIN 11850 butt weld ends

DIM	ØB	Wall thickness	ØA	ØE	D	L	F
	[MM]						
DN25	29	1.5	26.0	79.0	34	61.0	8x12
DN32	35	1.5	32.0	85.0	38	64.3	8x12
DN40	41	1.5	38.0	90.0	38	66.7	8x12
DN50	53	1.5	50.0	105.0	40	77.6	8x12
DN65	70	2.0	66.0	125.0	41	84.8	8x12
DN80	85	2.0	81.0	137.0	42	91.6	12x12
DN100	104	2.0	100.0	157.0	44	101.7	12x12
DN150	154	2.0	146.8	216.5	40	138.9	16x16

### SMS 3008 butt weld ends

DIM	ØB	Wall thickness	ØA	ØE	D	L	F
	[MM]						
DN20	25.0	1.20	22.6	79.0	34	61.0	8x12
DN40	38.0	1.20	35.6	85.0	38	74.3	8x12
DN50	51.0	1.20	48.6	105.0	40	77.6	8x12
DN65	63.5	1.60	60.3	112.0	40	84.8	8x12
DN80	76.1	1.60	72.9	125.0	41	91.6	8x12
DN100	101.6	2.00	97.6	157.0	44	101.7	12x12

## VALVE DATA

DIM [MM]	MAX. TORQUE [NM]	WEIGHT FREE STEM [KG]
DN20	12.7	1.15
DN25	12.7	1.18
DN32	12.7	1.22
DN40	12.7	1.28
DN50	16.9	1.32
DN65	19.5	1.66
DN80	26.0	1.94
DN100	39.0	3.00
DN150	45.5	7.60

Torque incl. 30% safety factor

## PRESSURE / TEMPERATURE

### Working pressure:

- -0.9 bar~10 bar

### Working temperature:

- Silicon: -20°C~210°C
- EPDM: -10°C~120°C
- Viton: -10°C~210°C