

SOLENOID VALVE IN-LINE (5/2-WAY)

TYPE DVC5237

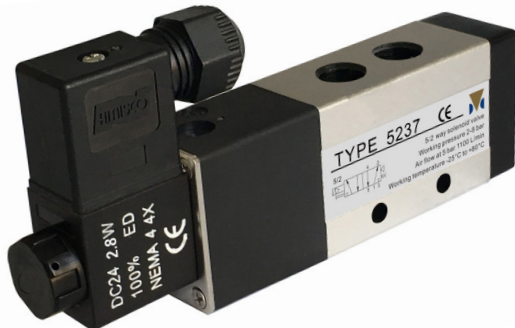

armatec



GENERAL

CONSTRUCTION:	5/2 - WAY (IN-LINE)
AIR FLOW:	1100 L/MIN AT 5 BAR Kv = 0.95 m ³ /h
AIR PRESSURE:	2 TO 8 BAR
COILS:	24V DC, 24V AC, 230V AC
POWER CONSUMPTION:	24V DC - 2.8W 24V AC - 4VA 230V AC - 4VA
AMBIENT TEMPERATURE:	-25°C TO 80°C
CONNECTIONS:	IN-LINE 1/4" INLET/OUTLET
MEDIA:	AIR OR INERT GAS
AIR QUALITY:	DIN/ISO 8573-1 CLASS3
CABLE GLAND:	M20 X 1.5
WIRE CONNECTION:	DIN 46244
PROTECTION CLASS:	IP66
SURFACE:	HARD ANODIZED ALUMINUM - 20µm
APPROVALS:	SIL3

OPTIONS

COIL:	110V AC, 120V AC
CONSTRUCTION:	DOUBLE COIL (BI-STABLE)
CONNECTION:	1/2" INLET/OUTLET FOR LARGE ACTUATORS

MOUNTING

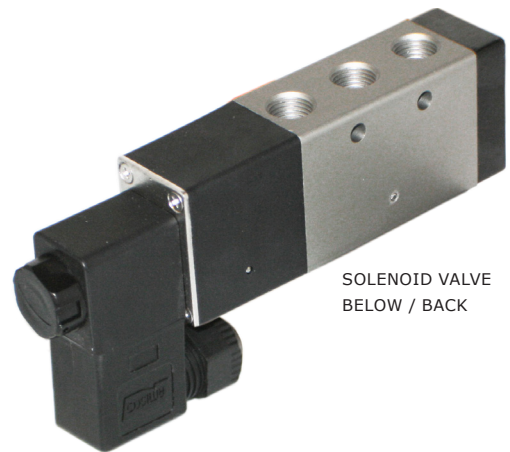
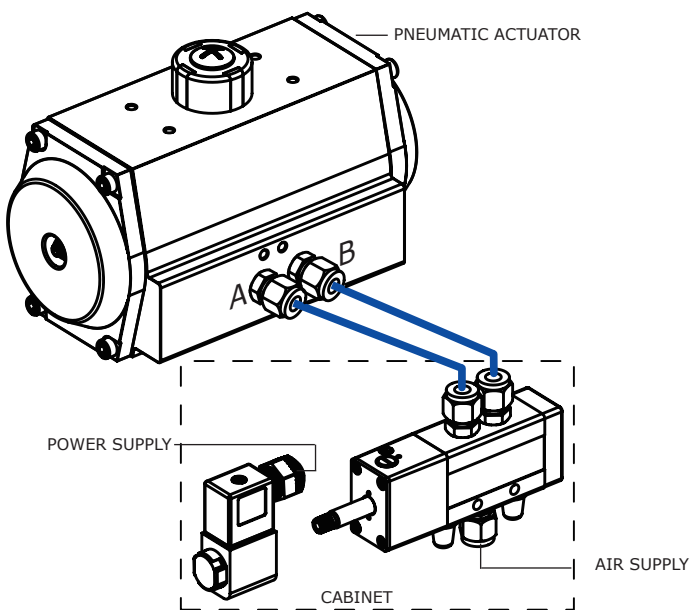

FITTINGS TYPE 5900

DESCRIPTION

- **Robust industrial 5/2 way solenoid valve.** Available in IP66 protection class.
- **Low power consumption** and long service life.
- **IN-LINE** construction for external mounting in a cabinet.
- **Surface is hard anodized aluminum** as protection against corrosion (20µm).
- **100% quality control.** Each solenoid valve is functional tested and pressure tested.
- **Manuel operation** for use in testing or when lack of supply voltage.
- **The spring return piston** ensures that the solenoid valve returns to its starting point at power failure.
- **Low temperature construction.** Can operate at -25°C.

DIMENSION AND MATERIALS

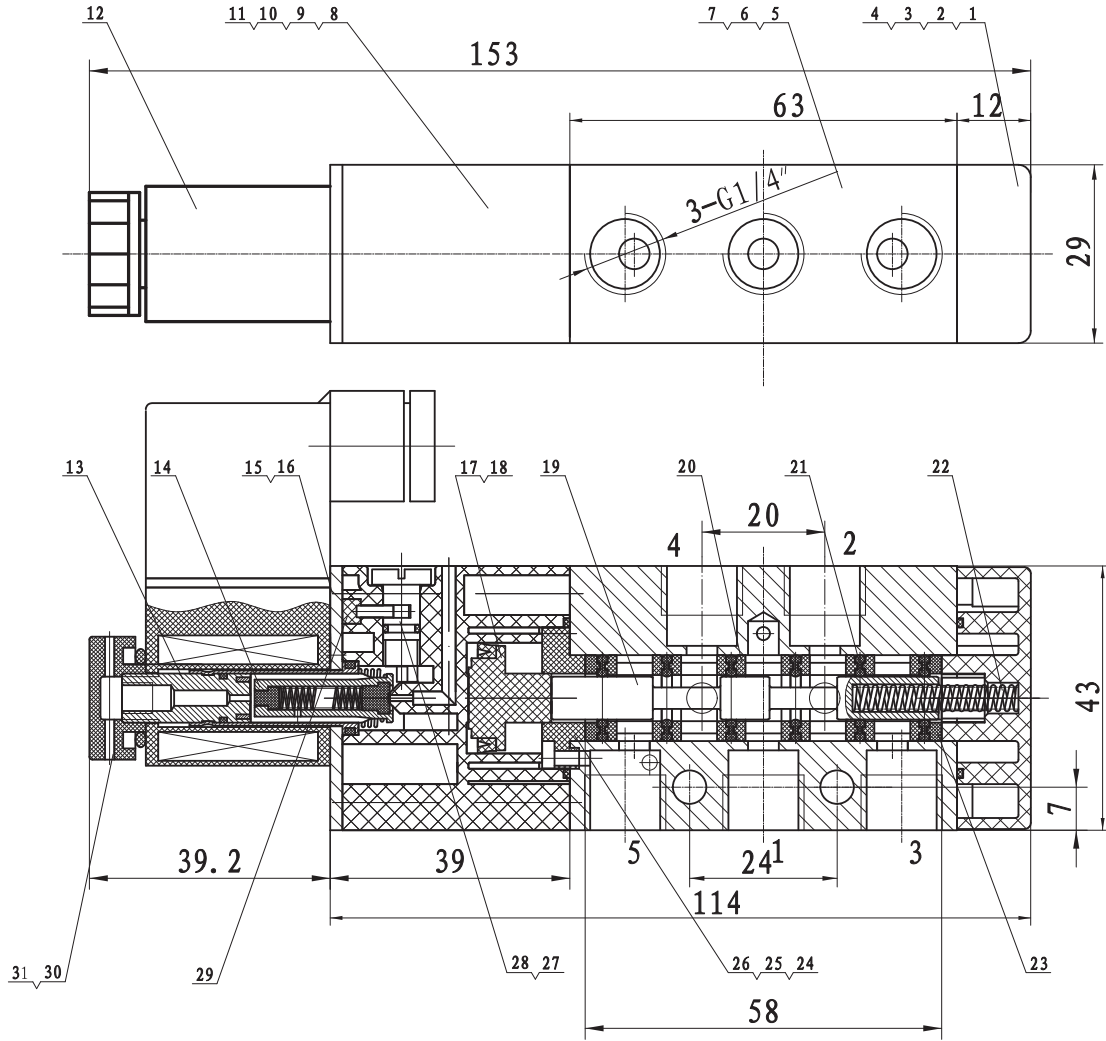

POS	DESCRIPTION	MATERIALS
1	SPRING END-CAP	Zn A14-1
2	END-CAP O-RING	NBR
3	M3X12 BOLT	AISI 304
4	WASHER	AISI 304
5	BODY	ALUMINUM (6063)
6	BALL	AISI 304
7	DUSTPROOF CAP	POLYETHYLENE
8	PISTON	PBT + 15% GLASS FIBER
9	BALL	AISI 304
10	M3X45 BOLT	AISI 304
11	PIN	AISI 304
12	STANDARD COIL	VARIOUS MATERIALS
13	FIXED MAGNETIC CORE	STAINLESS STEEL
14	MOVING MAGNETIC CORE	STAINLESS STEEL
15	COVER PLATE	AISI 303
16	PACKING	NBR

POS	DESCRIPTION	MATERIALS
17	PISTON O-RING	NBR
18	PISTON	REINFORCED NYLON
19	SPOOL	ALUMINUM (6063)
20	DISTANCE RING	PBT
21	SPOOL O-RING	NBR
22	RETURN SPRING	STAINLESS STEEL
23	SPOOL THROUGH-HOLE CAP	POM
24	SPOOL THROUGH-HOLE CAP	POM
25	DOUBLE HOLE O-RING	NBR
26	PISTON THROUGH-HOLE CAP	POM
27	HANDLE O-RING	NBR
28	OVERRIDE SWITCH	H62
29	PLUG	NBR
30	NUT	30% GLASS FIBER REINFORCED NYLON
31	2.4X10.8 O-RING	NBR

WIRING DIAGRAM

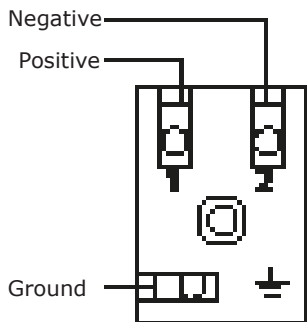

NOTE:
The wiring diagram is the same for VDC as well as VAC.

FUNCTION DIAGRAM

