

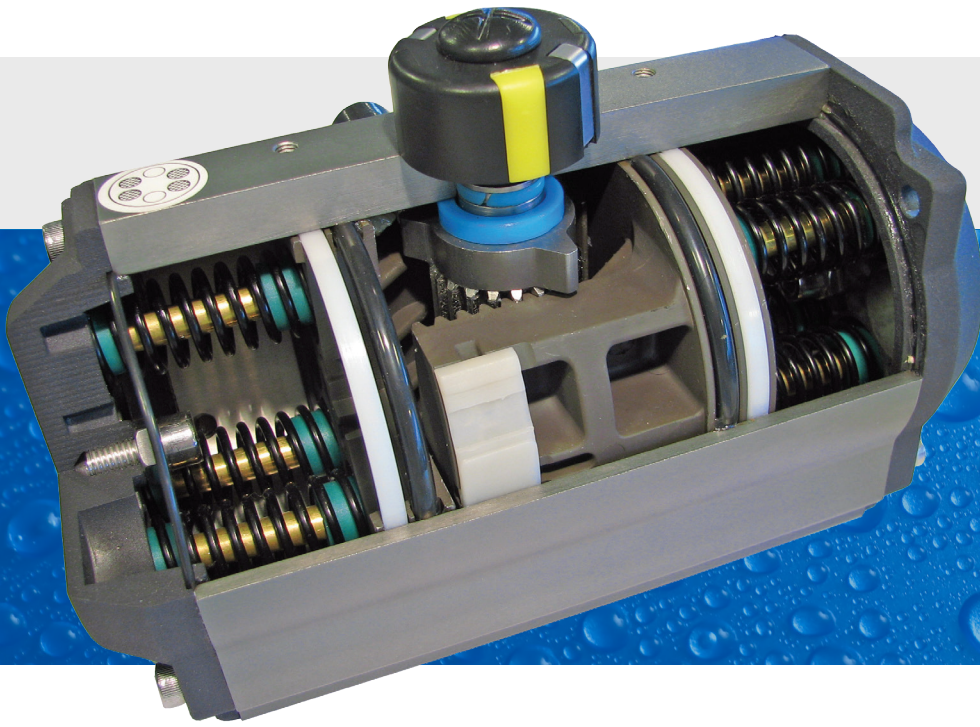

Valves with a difference



Pneumatic Actuators



With Dansk Ventil Center as your business partner, you are always guaranteed a wide and well sorted product range and a unique technical know-how.

Product development is a key factor for DVC, ensuring you the best products at any time.

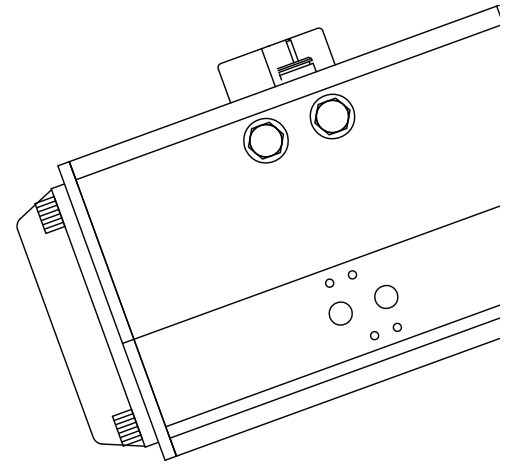

ATEX approved
CE approved
Long Service
Easy Adjustment
Standard Connections

What is important to you, when you buy pneumatic actuators? What about: CE-approved? ATEX approved? Long service? Large program? Value for money? Standard connections?

Pneumatic actuators from Dansk Ventil Center are characterized by their easy mounting and easy adjusting. The actuators are available in a wide range of dimensions and at competitive prices.

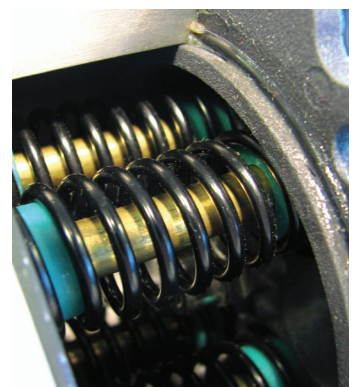
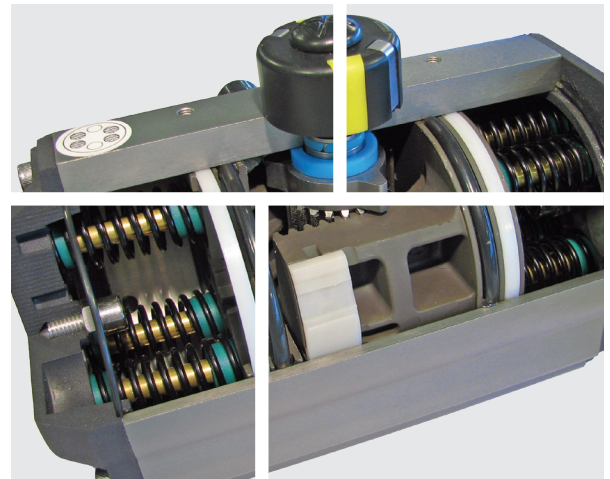

Indicator

Position indicator with VDI / VDE 3845 is convenient for mounting accessories such as Limit Switch boxes, positioners etc.

Actuator body

As standard hard anodized (40 μ) but can be supplied PTFE coated or all stainless.

Pistons

The twin rack piston are made from die-cast aluminium hard anodized or from galvanized cast steel. Reversing rotation possible by simply inverting the pistons. Symmetric mounting position gives a long life cycle and fast operation.

Pinion

The pinion is high-precision and integrative, made from nickel-plated carbon steel.

Travel adjustment

The two independent external travel stop adjustment bolts can easily and precisely adjust $\pm 5^\circ$ at both open and close directions.

High performance springs

Pre loaded coated springs are made from high quality material for corrosion resistance and long life cycle.

* Only in type 505 Spring Return.

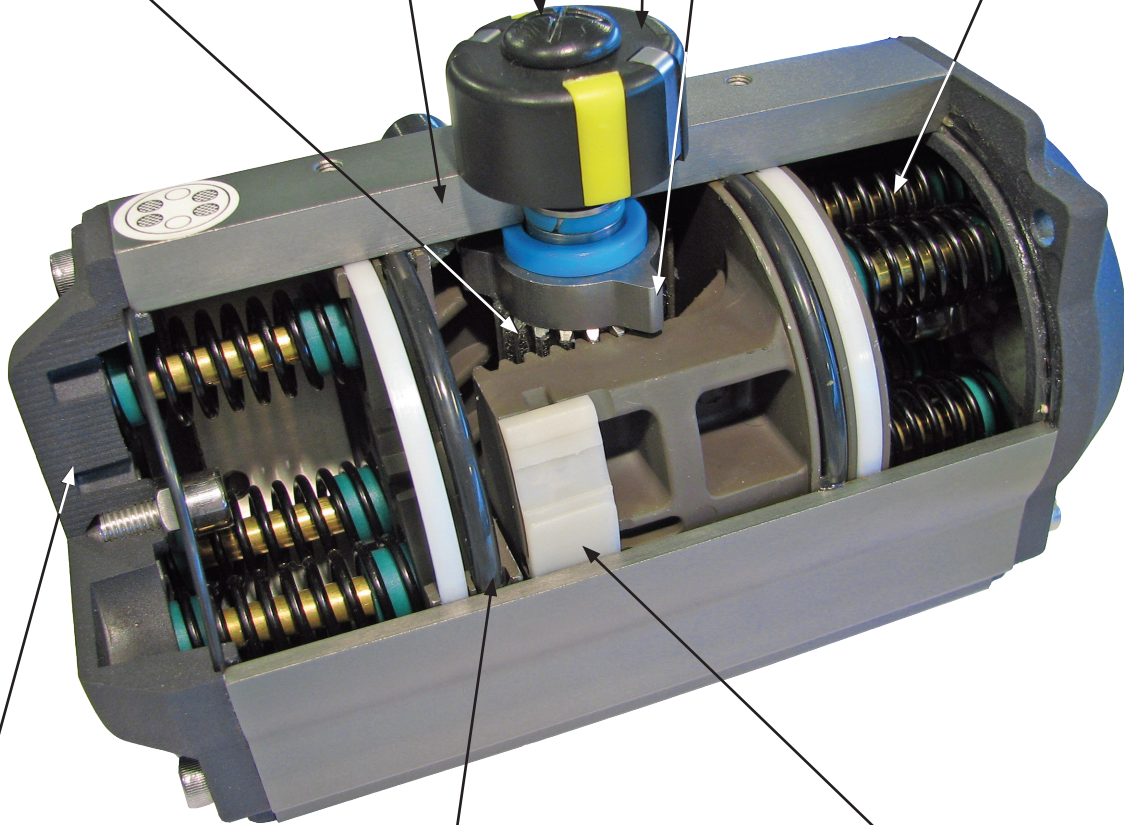

End caps

As standard die-cast aluminium powder polyester painted black. Can be supplied in different colours, PTFE coated or nickel plated

O-rings

NBR O-rings provide trouble-free operation at standard temperature ranges. For high and low temperature Viton or Silicone is used.

Bearings and guides

Made from low friction, long life compound material to avoid direct contact between metals. The maintenance and replacement are easy and convenient.

Type 505 DA and 505 SR - Dimensions

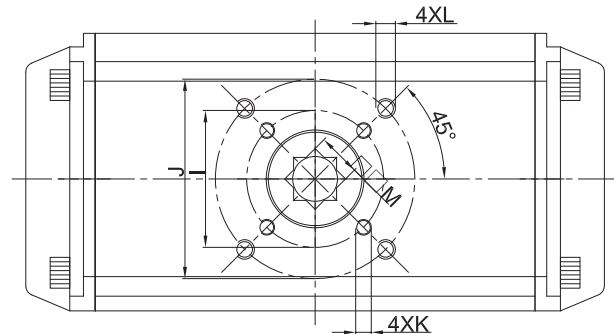
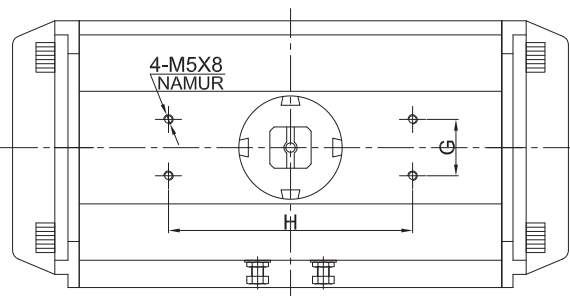
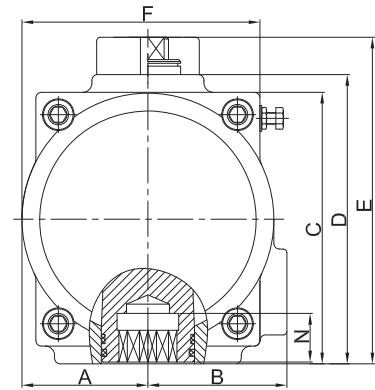
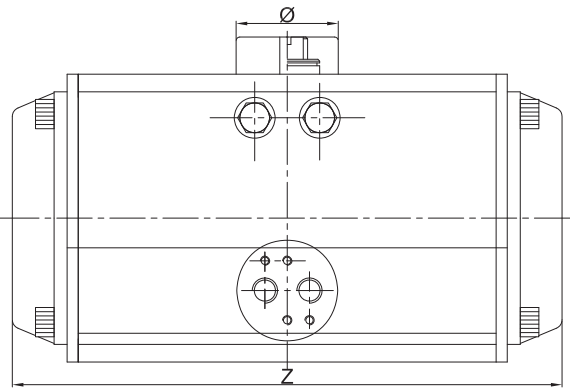

Double acting

Size	A	B	C	D	E	F	G	H	Double Acting		K	L	M	N	Z	Ø
	[MM]	[MM]	[MM]	[MM]	[MM]	[MM]	[MM]	[MM]	ISO - I	ISO - J	[MM]	[MM]	[MM]	[MM]	[MM]	[MM]
40	29	37	60	67	80	52	30	80	42 / F04		M5 x 8	M6 x 10	9 / 11	14	122	40
52	30	42	66	72	92	65	30	80	42 / F04	-	M5 x 8	-	11	14	147	40
52	30	42	66	72	92	65	30	80	36 / F03	50 / F05	M5 x 8	M6 x 10	11	14	147	40
63	36	47	81	88	108	72	30	80	50 / F05	70 / F07	M6 x 10	M8 x 13	14	18	168	40
75	42	53	94	100	120	81	30	80	50 / F05	70 / F07	M6 x 10	M8 x 13	14	18	184	40
83	46	57	99	109	129	92	30	80	50 / F05	70 / F07	M6 x 10	M8 x 13	17	21	204	40
92	50	59	111	117	137	98	30	80	50 / F05	70 / F07	M6 x 10	M8 x 13	22	26	262	40
105	58	64	123	133	153	110	30	80	70 / F07	102 / F10	M8 x 13	M10 x 16	22	26	268	40
125	68	75	146	155	175	128	30	80	70 / F07	102 / F10	M8 x 13	M10 x 16	22	26	301	55
140	75	77	161	172	192	138	30	80	102 / F10	125 / F12	M10 x 16	M12 x 20	27	31	390	55
160	87	87	184	197	217	158	30	80	102 / F10	125 / F12	M10 x 16	M12 x 20	27	31	458	55
190	103	103	216	230	260	189	30	130	140 / F14	-	M16 x 25	-	27	31	525	80
210	113	113	236	255	285	210	30	130	140 / F14	-	M16 x 25	-	36	40	532	80
240	130	130	265	288	318	245	30	130	165 / F16	-	M20 x 25	-	46	50	602	80
270	147	147	299	326	356	273	30	130	165 / F16	-	M20 x 25	-	46	50	722	80

Spring Return

Size	A	B	C	D	E	F	G	H	Spring Return		K	L	M	N	Z	Ø
	[MM]	[MM]	[MM]	[MM]	[MM]	[MM]	[MM]	[MM]	ISO - I	ISO - J	[MM]	[MM]	[MM]	[MM]	[MM]	[MM]
52	30	42	66	72	92	65	30	80	42 / F04	-	M5 x 8	-	9	14	147	40
52	30	42	66	72	92	65	30	80	36 / F03	50 / F05	M5 x 8	M6 x 10	11	14	147	40
63	36	47	81	88	108	72	30	80	36 / F03	50 / F05	M5 x 8	M6 x 10	11	14	168	40
75	42	53	94	100	120	81	30	80	36 / F03	50 / F05	M5 x 8	M6 x 10	11/14	14	184	40
83	46	57	99	109	129	92	30	80	50 / F05	70 / F07	M6 x 10	M8 x 13	14	18	204	40
92	50	59	111	117	137	98	30	80	50 / F05	70 / F07	M6 x 10	M8 x 13	17	21	262	40
105	58	64	123	133	153	110	30	80	70 / F07	102 / F10	M8 x 13	M10 x 16	17	26	268	40
125	68	75	146	155	175	128	30	80	70 / F07	102 / F10	M8 x 13	M10 x 16	22	26	301	55
140	75	77	161	172	192	138	30	80	102 / F10	125 / F12	M10 x 16	M12 x 20	22	26	390	55
160	87	87	184	197	217	158	30	80	102 / F10	125 / F12	M10 x 16	M12 x 20	22	26	458	55
190	103	103	216	230	260	189	30	130	125 / F12	-	M12 x 20	-	27	31	525	80
210	113	113	236	255	285	210	30	130	140 / F14	-	M16 x 25	-	27	31	532	80
240	130	130	265	288	318	245	30	130	140 / F14	-	M16 x 25	-	36	40	602	80
270	147	147	299	326	356	273	30	130	140 / F14	-	M16 x 25	-	36	40	722	80

■ Assembly and Parts

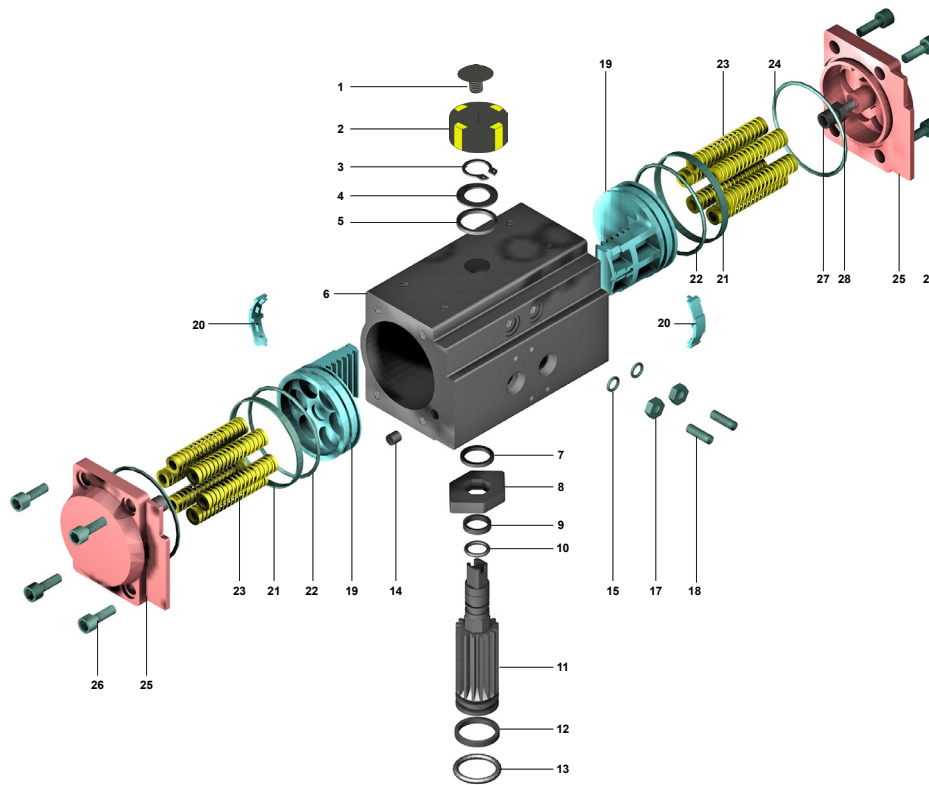

No.	Description	Quantity	Standard Material	Protection	Optional Material
1	Indicator Screw	1	Plastic ABS		
2	Indicator	1	Plastic ABS		
3	Spring Clip	1	Stainless Steel AISI 304		
4	Metal Washer	1	Stainless Steel AISI 304		
5	Outside Washer	1	Polyoxymethylene		
6	Body	1	Extruded Aluminium Alloy	Hard Anodized 40µ	
7	Inside Washer	1	Polyoxymethylene		
8	Travel Stop	1	Alloy Steel		
9	O-ring (Pinion Top)	1	NBR		FPM / Silicone
10	Bearing (Pinion Top)	1	Polyoxymethylene		
11	Pinion	1	Carbon Steel	Nickle Plated	Stainless Steel 304, 316
12	O-ring (Pinion Bottom)	1	Polyoxymethylene		
13	Bearing (Pinion Bottom)	1	NBR		FPM / Silicone
14	Hole sealant	2	NBR		FPM / Silicone
15	O-ring (Adjustment Screw)	2	NBR		FPM / Silicone
17	Nut (Adjustment Screw)	2	Stainless Steel AISI 304		
18	Adjustment Screw	2	Stainless Steel AISI 304		
19	Piston	2	Aluminium Casting 101A	Hard anodized	Calvanized Cast Steel (sizes 105, 125, 140 & 160)
20	Plate (Piston)	2	Polyoxymethylene		
21	Bearing (Piston)	2	Polyoxymethylene		
22	O-ring (Piston)	2	NBR		FPM / Silicone
23	Spring (only on type 505)	0 - 12	Spring Steel	Dip Coated	
24	O-ring (End Cap)	2	NBR		FPM / Silicone
25	End Cap	2	Aluminium Casting ADC12	Powder Polyester Painted	
26	Cap Screw	8	Stainless Steel AISI 304		
27	Stop Screw	2	Stainless Steel AISI 304		
28	Nut (Stop Screw)	2	Stainless Steel AISI 304		

Double Acting Actuators

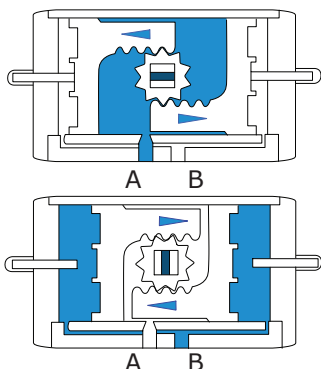

CCW: Air to Port A forces the pistons outwards, causing the pinion to turn counter clockwise while the air is being exhausted from Port B.

Air to Port B forces the pistons inwards, causing the pinion to turn clockwise while the air is being exhausted from Port A.

CCW is standard at Dansk Ventil Center

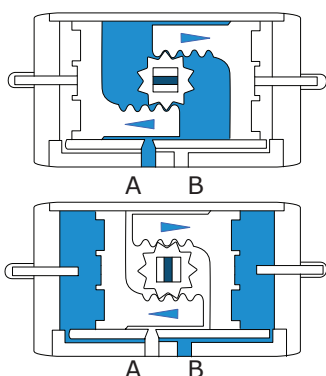

CW: Air to Port A forces the pistons outwards, causing the pinion to turn clockwise while the air is being exhausted from Port B.

Air to Port B forces the pistons inwards causing the pinion to turn counter clockwise while the air is being exhausted from Port A.

Output Torque - Double Acting Actuators (Unit: Nm)

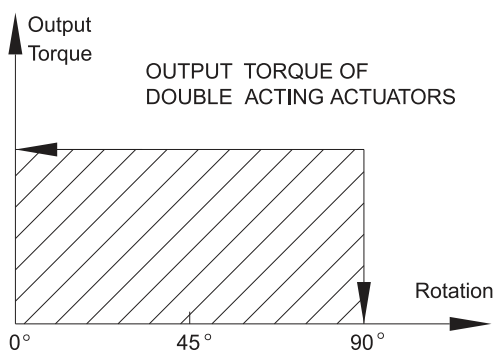

Size	Air Supply Pressure (Unit: Bar)									
	2	2.5	3	4	4.5	5	5.5	6	7	8
40	4.8	6.0	7.2	9.5	10.7	11.9	13.1	14.3	16.7	19.1
52	8.0	10.0	12.0	16.0	18.0	20.0	21.9	23.9	27.9	31.9
63	14.6	18.2	21.9	29.2	32.8	36.5	40.1	43.8	51.1	58.4
75	20.1	25.1	30.1	40.1	45.1	50.2	55.2	60.2	70.2	80.3
83	31.4	39.2	47.0	62.7	70.5	78.4	86.2	94.1	109.7	125.4
92	45.1	56.4	67.7	90.3	101.6	112.9	124.1	135.4	158.0	180.6
105	66.1	82.7	99.2	132.2	148.8	165.3	181.8	198.4	231.4	264.5
125	100.3	125.4	150.5	200.6	225.7	250.8	275.9	301.0	351.1	401.3
140	171.0	213.8	256.5	342.0	384.8	427.5	470.3	513.0	598.5	684.0
160	266.0	332.5	399.0	532.0	598.5	665.0	731.5	798.0	931.0	1064.0
190	425.6	532.0	638.4	851.2	957.6	1064.0	1170.4	1276.8	1489.6	1702.4
210	532.0	665.0	798.0	1064.0	1197.0	1330.0	1463.0	1596.0	1862.0	2128.0
240	769.5	961.9	1154.3	1539.0	1731.4	1923.8	2116.1	2308.5	2693.3	3078.0
270	1169.6	1462.1	1754.5	2339.3	2631.7	2924.1	3216.5	3508.9	4093.7	4678.6

■ Sizing - Double Acting Actuators

The suggested safety factor for double acting actuators under normal working conditions is 20% - 30%.

Example:

- The torque needed by valve = 100 Nm.
- The torque considered safety factor (1 + 30%) = 130 Nm.
- Air supply = 5 bar.

According to the output torque table on double acting actuators the smallest model we can choose is Model 105.

■ Sizing - Double Acting Actuators for Butterfly Valves

Actuator size	Air Supply Pressure Nm at 6 bar	ISO 5211 / mm	Product no.	BV Dimensions	BV Torque Nm	ISO 5211 / mm
40	9.2	F04 / 9 F04 / 11	50500 40 449 50500 40 441			
52	23.9	F04 / 11 F03-F05 / 11	50500 52 441 50500 52 351	DN 50 DN 65	10.0 16.2	F05 / 11
63	43.8	F05-F07 / 14	50500 63 574	DN 80 DN 100	23.7 35.0	F05 / 11 F05 - F07 / 14
75	60.2	F05-F07 / 14	50500 75 574	DN 125	58.7	F07 / 14
83	94.1	F05-F07 / 17	50500 83 577	DN 150	83.7	F07 / 17
92	135.4	F05-F07 / 22	50500 92 572			
105	198.4	F07-F10 / 22	5050 105 702	DN 200	163.7	F10 / 22
125	301.0	F07-F10 / 22	5050 125 702	DN 250	280.0	F10 / 22
140	513.0	F10-F12 / 27	5050 140 028	DN 300	401.2	F10-F12 / 27
160	798.0	F10-F12 / 27	5050 160 028	DN 350	770.0	F12-F14 / 27
190	1276.0	F14 / 27	5050 190 888	DN 400	1093.7	F12-F14 / 27
210	1596.0	F14 / 36	5050 210 883	DN 450	1496.2	F14-F16 / 36
240	2308.5	F16 / 46	5050 240 665	DN 500	1987.5	F14-F16 / 46
270	3508.9	F16 / 46	5050 270 665	DN 600	3263.7	F16-F25 / 46

The torque for the butterfly valves are with a safety factor of 25%. Please remember that the actuator torque is based on an air supply of 6 bar at the actuator position.

Spring Return Actuators

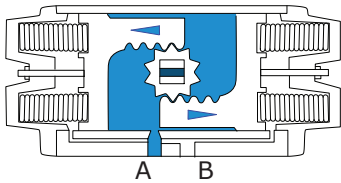

CCW: Air to Port A forces the pistons outwards, causing the springs to compress. The pinion turns counter clockwise while the air is being exhausted from Port B.

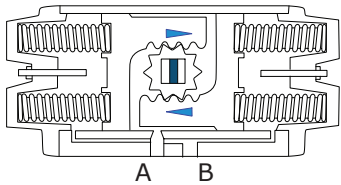

Loss of air pressure on Port A, the stored energy in the springs forces the pistons inwards. The pinion turns clockwise while air is being exhausted from Port A.

CCW is standard at Dansk Ventil Center

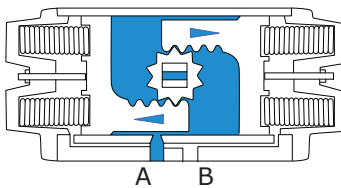

CW: Air to Port A forces the pistons outwards, causing the springs to compress. The pinion turns clockwise while the air is being exhausted from Port B.

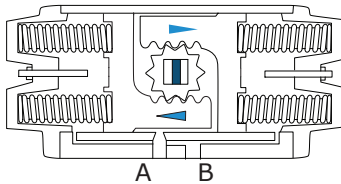

Loss of air pressure on Port A, the stored energy in the springs forces the pistons inwards. The pinion turns counter clockwise while air is being exhausted from Port A.

Output Torque - Spring Return Actuators (Unit: Nm)

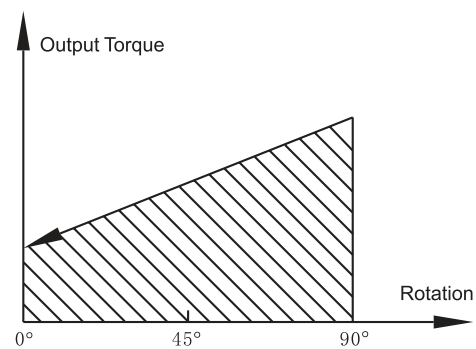
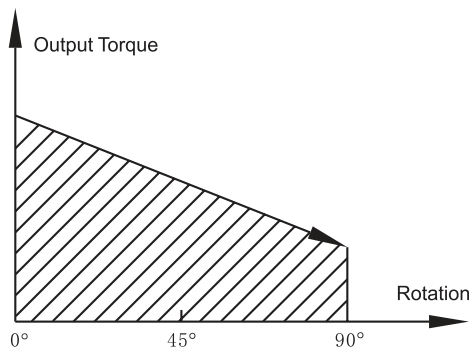

Type 505 Spring Return - Torque



Output Torque of Spring Return Actuators (Unit: Nm)																	Spring Output	
Air Pressure		2.5 bar		3 bar		4 bar		5 bar		6 bar		7 bar		8 bar		90°	0°	
Size	Spring Qty.	0°	90°	0°	90°	0°	90°	0°	90°	0°	90°	0°	90°	0°	90°			
		Start	End	Start	End	Start	End	Start	End	Start	End	Start	End	Start	End			
52	5	5.7	3.8	7.6	5.7											6.2	4.3	
	6	4.9	2.5	6.9	4.5	10.9	8.5									7.4	5.0	
	7	4.0	1.3	6.0	3.3	9.8	7.3	14.0	10.4							8.6	5.9	
	8			5.2	2.0	9.2	6.0	13.2	9.1	17.2	14.1					9.9	6.7	
	9			4.3	0.8	8.3	4.8	12.3	7.9	16.3	12.8	20.3	16.8			11.1	7.6	
	10					7.4	3.6	11.5	6.7	15.5	11.6	19.5	15.6			12.4	8.5	
	11					6.6	2.3	10.6	5.4	14.6	10.4	18.6	14.3	22.6	18.3	13.6	9.3	
	12 *							9.7	4.2	13.8	9.1	17.8	12.2	21.8	17.1	14.8	10.2	
63	5	11.4	7.7	15.0	11.4	22.3	14.9									10.4	6.8	
	6	10.1	5.7	13.6	9.3	20.9	16.6	28.3	23.9							12.5	8.2	
	7	8.6	3.6	12.5	7.2	19.5	14.5	26.8	21.9							14.6	9.6	
	8			10.9	5.1	18.2	12.4	25.5	19.8	32.8	27.0	40.1	34.3			16.7	10.9	
	9					16.8	10.4	24.1	17.7	31.4	24.9	38.7	32.2			18.8	12.3	
	10					1.4	8.2	22.8	15.6	30.0	22.8	37.3	30.1	44.7	37.4	20.9	13.7	
	11							21.5	13.5	28.7	20.7	36.0	28.0	43.3	35.3	22.9	15.0	
	12 *							20.0	11.4	27.3	18.6	34.6	25.9	41.9	33.3	25.0	16.4	
75	5	14.5	10.6	19.4	15.5	29.5	25.7									14.5	10.5	
	6	12.4	7.6	17.3	12.6	27.4	22.7	37.5	32.8							17.4	12.7	
	7	10.4	4.8	15.2	9.7	25.3	19.9	35.4	29.9							20.3	14.8	
	8			13.1	6.8	23.1	16.9	33.3	27.0	43.2	37.0	53.3	47.0			23.2	16.9	
	9					21.0	14.1	31.2	24.1	41.1	34.1	51.2	44.2			26.1	19.0	
	10					19.0	11.1	28.8	21.2	39.0	31.2	49.1	41.2	59.1	51.2	29.0	21.1	
	11							27.0	18.3	37.0	28.3	47.0	38.4	57.0	48.4	31.9	23.2	
	12 *							24.9	15.4	34.9	25.4	44.9	35.4	54.9	45.4	34.7	25.3	
83	5	23.3	16.1	31.1	24.0	46.8	39.7									23.0	15.8	
	6	20.1	11.5	28.0	19.3	43.7	35.1	59.4	50.7							27.6	19.0	
	7	17.0	6.9	24.8	14.8	40.5	30.5	56.2	46.2							32.2	22.1	
	8			21.7	10.1	37.4	25.8	53.1	41.5	68.8	57.2	84.5	72.9			36.8	25.3	
	9					34.2	21.3	49.9	37.0	65.6	52.6	81.2	68.3			41.4	28.5	
	10					31.0	16.6	46.7	32.3	62.4	48.0	78.1	63.7	93.8	79.3	46.0	31.6	
	11							43.6	27.7	59.3	43.4	75.0	59.1	90.6	74.8	50.6	34.8	
	12 *							40.4	23.2	56.1	38.9	71.7	54.5	87.4	70.2	55.2	38.0	
92	5	33.1	22.0	44.2	33.2	66.8	55.9									34.4	23.3	
	6	28.4	15.2	39.6	26.4	62.2	49.0	84.8	71.6							41.2	28.0	
	7	23.8	8.2	34.9	19.4	57.5	42.1	80.2	64.7							48.1	32.7	
	8			31.3	12.6	52.9	35.2	75.5	57.9	98.1	80.5	120.7	103.0			55.0	37.3	
	9					48.2	28.4	70.9	51.0	93.5	73.6	116.0	96.1			61.9	42.0	
	10					43.6	21.5	66.2	44.1	88.8	66.7	111.3	89.2	134.0	111.8	68.7	46.7	
	11							61.5	37.2	84.1	59.9	106.6	82.4	129.2	105.0	75.6	51.4	
	12 *							56.8	30.4	79.4	53.0	101.9	75.5	124.5	98.1	82.5	56.0	
105	5	51.0	33.4	67.5	49.9	100.6	83.0									49.2	31.6	
	6	44.7	23.5	61.1	40.0	94.2	73.2	127.3	106.2							59.1	38.0	
	7	38.4	13.7	54.9	30.3	87.9	63.4	121.0	96.4							68.9	44.3	
	8			48.5	20.4	81.6	53.5	114.7	86.5	147.7	114.7	180.8	152.7			78.7	50.6	
	9					75.3	43.7	108.4	76.8	141.5	109.8	174.5	142.9			88.6	56.9	
	10					68.9	33.4	102.0	66.5	135.1	99.6	168.2	132.6	201.2	165.7	98.4	63.3	
	11							95.7	57.0	128.7	90.1	161.8	123.1	194.8	156.2	108.3	69.6	
	12 *							89.4	47.5	122.5	80.6	155.5	113.6	188.6	146.7	118.1	75.9	
125	5	73	47	98	72	148	122									79	52	
	6	63	31	88	56	138	107	188	157							94	63	
	7	52	15	77	40	127	90	178	141							110	73	
	8			67	25	117	75	167	125	217	176	268	226			125	84	
	9					107	59	157	109	207	159	257	210			141	94	
	10					96	44	146	94	196	144	247	194	297	245	157	105	
	11							136	78	186	128	236	178	286	228	173	115	
	12 *							125	63	176	113	226	163	276	213	188	125	

* Dansk Ventil Center standard

Type 505 Spring Return - Torque



Output Torque of Spring Return Actuators (Unit: Nm)																	Spring Output	
Air Pressure		2.5 bar		3 bar		4 bar		5 bar		6 bar		7 bar		8 bar		90°		0°
Size	Spring Qty.	0°	90°	0°	90°	0°	90°	0°	90°	0°	90°	0°	90°	0°	90°	90°	0°	
		Start	End	Start	End	Start	End	Start	End	Start	End	Start	End	Start	End	Start	End	
140	5	128	85	171	127	256	213									129	86	
	6	111	59	154	102	239	187	325	273							155	103	
	7	94	33	137	76	222	162	308	247							181	120	
	8			120	50	205	136	291	221	376	307	462	392			206	137	
	9					187	110	273	196	358	281	444	367			232	155	
	10					170	84	256	169	341	255	427	340	512	426	258	172	
	11							238	143	324	229	409	314	495	400	284	189	
	12 *							221	118	307	203	392	289	478	374	310	206	
160	5	193	124	259	191	392	324									208	140	
	6	165	83	232	149	365	282	498	415							255	168	
	7	137	41	203	107	336	240	169	373							292	196	
	8			176	66	309	199	442	237	575	465	708	598			333	223	
	9					280	157	413	290	546	423	679	556			375	251	
	10					253	115	368	248	519	381	652	514	785	647	417	279	
	11							358	207	491	340	624	473	757	606	458	307	
	12 *							330	165	463	298	596	431	729	564	500	335	
190	5	332	222	438	329	651	542									309	200	
	6	292	161	398	267	611	480	824	693							371	240	
	7	252	99	358	205	571	418	784	631							433	280	
	8			318	143	531	356	744	569	957	782	1169	995			495	320	
	9					491	295	704	507	917	720	1130	933			557	360	
	10					451	233	664	446	877	658	1090	871	1302	1084	618	400	
	11							624	384	837	597	1050	809	1263	1022	680	440	
	12 *							584	322	797	535	1010	748	1223	960	742	480	
210	5	390	285	523	418	789	684									380	275	
	6	335	209	468	342	734	608	1000	874							456	330	
	7	280	133	413	266	679	532	945	798							532	385	
	8			358	190	624	456	890	722	1156	988	1422	1254			608	440	
	9					569	380	835	646	1101	912	1367	1178			684	495	
	10					514	304	780	570	1046	836	1312	1102	1578	1368	760	550	
	11							725	494	991	760	1257	1026	1523	1292	836	605	
	12 *							670	418	936	684	1202	950	1468	1216	912	660	
240	5	552	409	744	600	1129	985									554	410	
	6	470	297	662	489	1047	874	1432	1259							665	492	
	7	388	187	580	379	964	764	1349	1149							775	575	
	8			498	268	883	653	1267	1037	1652	1422	2037	1807			886	656	
	9					800	542	1185	926	1569	1311	1954	1696			998	739	
	10					718	431	1103	816	1488	1201	1872	1586	2257	1970	1108	821	
	11							1021	705	1406	1090	1791	1474	2176	1859	1219	903	
	12 *							939	594	1323	979	1708	1363	2093	1748	1330	985	
270	5	903	675	1195	968	1779	1552									787	560	
	6	790	519	1083	811	1667	1396	2252	1981							943	672	
	7	679	361d	972	654	1556	1238	2141	1823							1101	783	
	8			860	497	1444	1081	2029	1666	2614	2252	3199	2836			1258	895	
	9					1332	923	1917	1509	2502	2094	3087	2678			1416	1007	
	10					1220	767	1085	1352	2390	1937	2974	2521	3560	3107	1572	1119	
	11							1693	1194	2278	1779	2826	2364	3448	2949	1730	1231	
	12 *							1582	1037	2167	1623	2751	2207	3336	2792	1887	1342	

* Dansk Ventil Center standard

■ Sizing - Spring Return Actuators

The suggested safety factor for spring return actuators under normal working conditions is 30% - 50%.

Example:

- The torque needed by valve = 80 Nm.
- The torque considered safety factor $(1 + 30\%) = 104$ Nm.
- Air supply = 5 bar.

According to the output torque table on spring return actuators, we find the output torque to be:

- Air stroke $0^\circ = 308$ Nm.
- Air stroke $90^\circ = 247$ Nm.
- Spring stroke $0^\circ = 181$ Nm.
- Spring stroke $90^\circ = 120$ Nm.

All the output torques are higher than needed.

■ Spring Mounting Form for Spring Return Actuators

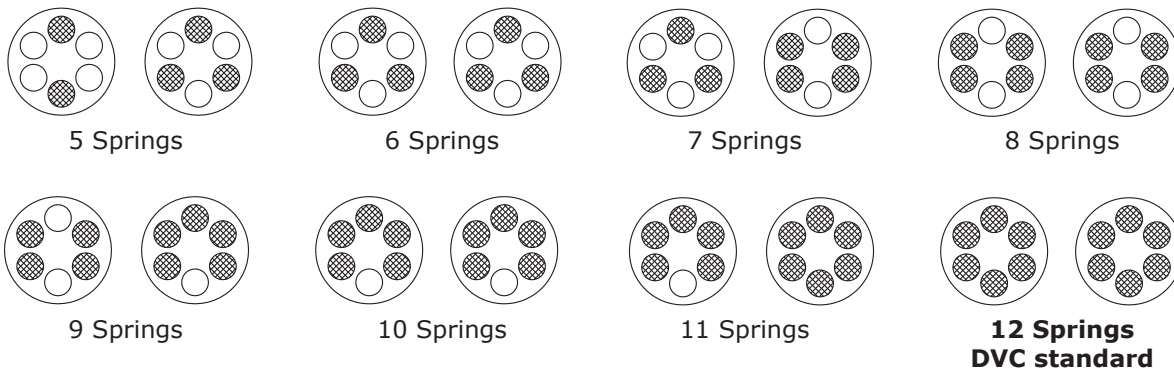

■ The most reasonable and economical actuators

If we know the torque needed by the valve while working at opening, operating and closing, we can choose the most reasonable and economical actuator.

Example:

- The maximum torque needed by the butterfly valve = 104 Nm.
- The torque after opened (operating) $104 \times 30\% = 32$ Nm.
- Air supply = 5 bar.

We can select the Model 125 Spring Return when the output torque is:

- Air stroke $0^\circ = 136$ Nm > 104 Nm.
- Air stroke $90^\circ = 78$ Nm > 32 Nm.
- Spring stroke $0^\circ = 173$ Nm > 32 Nm.
- Spring stroke $90^\circ = 115$ Nm > 104 Nm.
- The above data shows that the actuator torque can meet the requirements of the butterfly valve.

■ Sizing - Spring Return Actuators for Butterfly Valves

Actuator size	Spring Output Nm Start - End	ISO 5211 / mm	Product no.	BV Dimensions	BV torque Nm	ISO 5211 / mm
52	13.8 - 9.1 14.8 - 10.2	F03-F05 / 11	5051052351	DN 40 DN 50	11.3 12.5	F05 / 11
63	27.3 - 18.6 25.0 - 16.4	F03-F05 / 11	5051063351	DN 65	16.2	F05 / 11
75	34.9 - 25.4 34.7 - 25.3	F03-F05 / 11 + 14	5051075351	DN 80	23.7	F05 / 11
83	56.1 - 38.9 55.2 - 38.0	F05-F07 / 14	5051083574	DN 100	35.0	F05 - F07 / 14
92	79.4 - 53.0 82.5 - 56.0	F05-F07 / 17	5051092577			
105	112.5 - 80.6 118.1 - 75.9	F07-F10 / 17	5051105707	DN 125	58.7	F07 / 14
125	176.0 - 113.0 188.0 - 125.0	F07-F10 / 22	5051125702	DN 150	83.7	F07 / 17
140	307.0 - 203.0 310.0 - 206.0	F10-F12 / 22	5051140022	DN 200	163.7	F10 / 22
160	463.0 - 298.0 500.0 - 335.0	F10-F12 / 22	5051160022	DN 250	280.0	F10 / 22
190	797.0 - 535.0 742.0 - 480.0	F12 / 27	5051190228	DN 300	401.2	F10-F12 / 27
210	936.0 - 684.0 912.0 - 660.0	F14 / 27	5051210888			
240	1323.0 - 979.0 1330.0 - 985.0	F14 / 36	5051240883	DN 350	770.0	F12-F14 / 27
270	2167.0 - 1623.0 1887.0 - 1342.0	F14 / 36	5051270883	DN 400	1093.7	F12-F14 / 27

The torque for the butterfly valves are with a safety factor of 25%. Please remember that the actuator torque is based on an air supply of 6 bar at the actuator position.

Air Consumption

Air Volume Opening & Closing		
Model	Air Volume Opening	Air Volume Closing
52	0.12	0.16
63	0.21	0.23
75	0.30	0.34
83	0.43	0.47
92	0.64	0.73
105	0.95	0.88
125	1.60	1.40
140	2.50	2.20
160	3.70	3.20
190	5.90	5.4
210	7.50	7.50
240	11.00	9.00
270	17.00	14.00

Model 52 - 240:

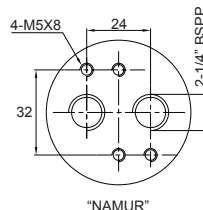

Model 270:

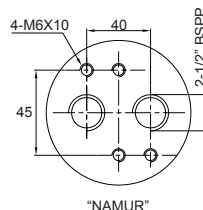

Air consumption depends on air supply. Air volume and action cycle times are calculated as below:
 $L/Min = \text{Air volume (opening + closing)} \times [\text{Air supply (Kpa)} + 101.3 / 101.3] \times \text{action cycle times (/min)}$

Mounting connections

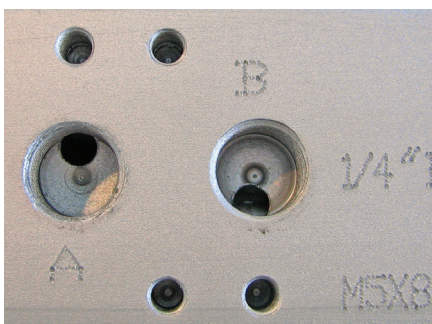

The air supply connection is designed in accordance with the NAMUR standard for installing solenoid valves.



The bottom mounting connection is designed in accordance with the ISO5211 and DIN3337 standards for direct mounting with valve worm gear boxes or mounting brackets.



The NAMUR drive pinion and the NAMUR top mounting connection permit direct installation of accessories such as limit switch boxes and positioners.



Each actuator is marked with air connection and bottom mounting holes are marked for easy track and distinction.

■ Quick Bracket

Adjustable

Type 5740 can easily be adjusted to various dimensions of valves ranging from 42 mm - 97 mm in height. F03 - F10 (ISO 5211 top / bottom flange).

Easy mounting

Type 5740 has an uncomplicated construction and is therefore very easy to mount even with pneumatic tools, just separate the top part from the bottom part (see illustration).

Easy maintenance

Type 5740 requires no tools for maintenance.

Safety

During maintenance it is easy to click of the actuator making sure that the valve can not be activated unintentionally - simply pull the two handles outwards and lift the actuator incl. the attached top part of the bracket (see illustration).

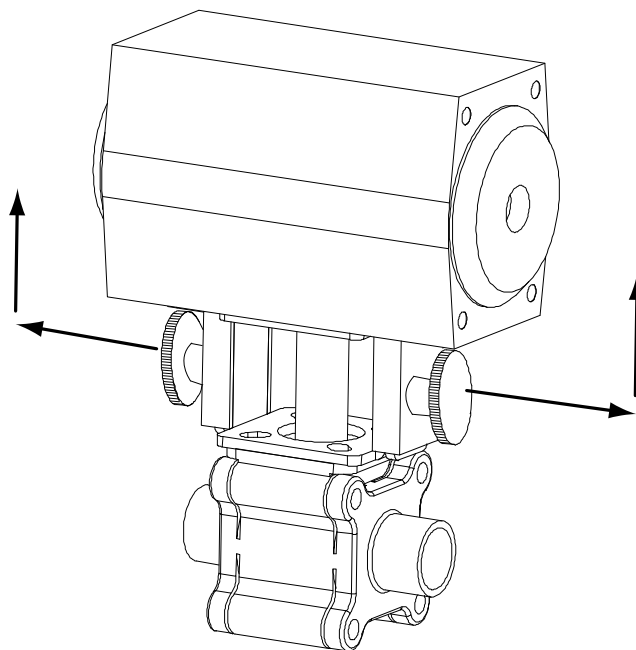

■ Bracket

Easy mounting

Type 5700 has an uncomplicated construction and is therefore very easy to mount even without pneumatic tools.

No maintenance

Type 5700 requires no maintenance.

Heavy-duty

Type 5700 has a robust design and is made of AISI 304.

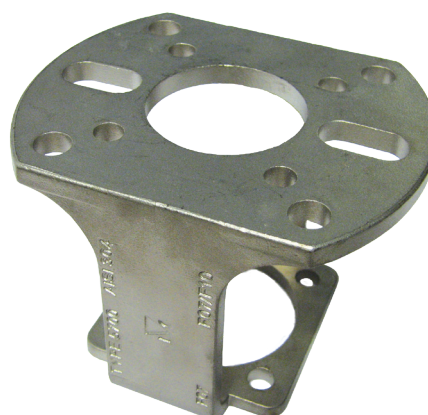
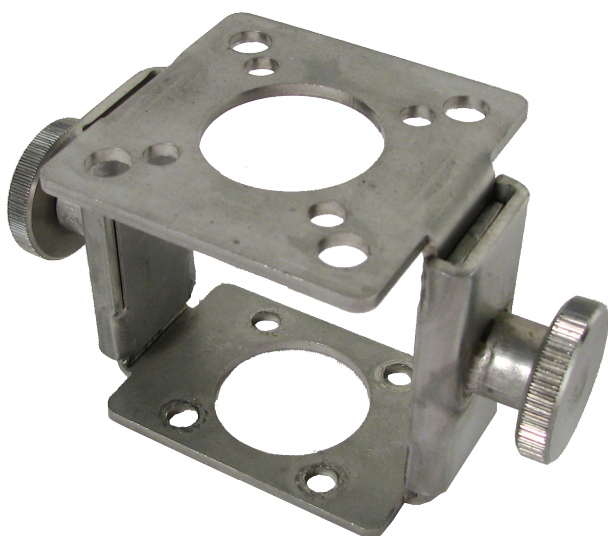
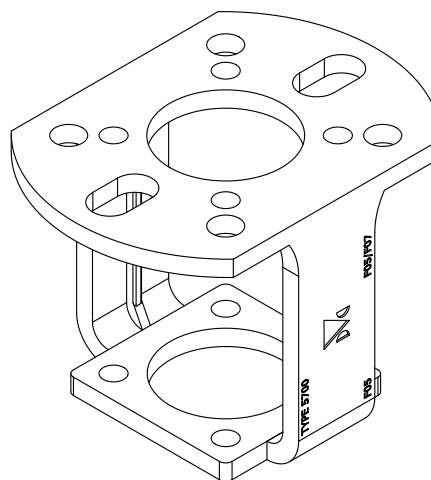

■ Limit Switch - Mechanical



Body in corrosion resistant and impact resistant aluminium. Powder coated.

Supplied with standard mounting bracket and cable connection.

Tightness Class IP67 as standard and IP68 as option.

Excellent visual indication of open or closed valve. Can be changed to suite rotation direction.

Approvals according to UL, CSA, SEMKO, SEV EN61058-1 and CE standards.

Supplied with mechanical switch set as standard. Can be supplied with inductive sensors PNP / NPN with various voltage.

■ Limit Switch - Inductive Double Sensor

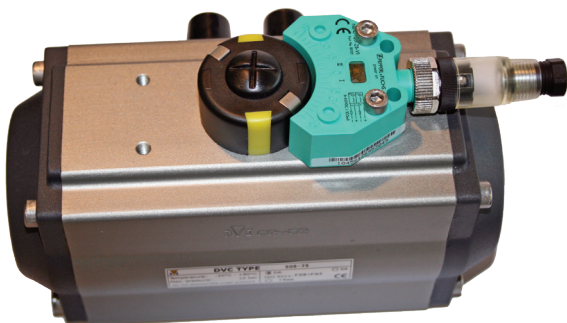

Short circuit protection.

Can be supplied with ATEX.

Complies with EN 60947-5-2, connection equipment for low voltage.

Excellent visual indication of open and closed valve.

Made of corrosion resistant material (glass fibre reinforced plastic).

Easy mounting.

■ Solenoid Valve NAMUR

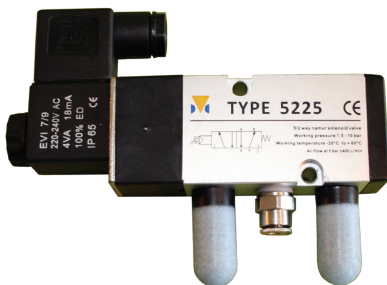

Low power consumption and long service life.

Surface is hard anodised - 20µ.

Locking device.

NAMUR standard for direct mounting on actuators.

CE approved.

Each solenoid valve is function tested and pressure tested.



Know-how makes the difference

Dansk Ventil Center A/S

Product Range

- Ball Valves
- Butterfly Valves Soft Seated
- Butterfly Valves Metal Seated
- Angle Seat Valves
- Thin Wafer Check Valves
- Safety Valves
- Knife Gate Valves
- Pneumatic Actuators
- Electrical Actuators
- Brackets for Actuators
- Limit Switches
- Level Gauges - Reflex & Transparent
- Control Valves
- Pressure Reducing Valves

Dansk Ventil Center is committed to meeting the needs of customers in an environmentally sound and sustainable manner, through continuous improvements in environmental performance in all our activities.

Dansk Ventil Center is located in the northern part of Europe, in the heart of Denmark.

Visit us at www.dvcas.dk and learn more about Dansk Ventil Center and our products.

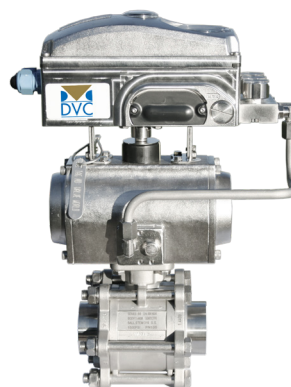

...for very harsh environments DVC offers completely Stainless Steel assemblies.

- Valves
- Solenoid valve
- Electro Pneumatic positioner
- Pneumatic actuator
- Mechanical switch box
- Filter regulator

Dansk Ventil Center A/S

Ferrarivej 14
DK-7100 Vejle
Denmark

Tel.: +45 75 72 33 00
Fax: +45 75 72 75 15
E-mail: mail@dvcas.dk
Web: www.dvcas.dk

