

3-PCS BALL VALVE - PREMIUM

TYPE 1251: STEEL
TYPE 1351: STAINLESS STEEL



econ

GENERAL

SIZE/PRESSURE: 1/4" - 4"
 PRESSURE: SEE PAGE 2, VALVE DATA
 TEMPERATURE: -40°C TO 250°C (STAINLESS STEEL)
 -29°C TO 250°C (STEEL)
 (PRESSURE AND TEMPERATURE ARE INTERDEPENDENT)
 ISO TOP FLANGE: ISO 5211
 THREAD ENDS: BSPP - EN ISO 228-1
 BUTT WELD ENDS: TYPE 1251 - EN 12627
 TYPE 1351 - ISO 1127 LINE 1, SMS 3008
 BALL SURFACE HARDENING: 300HV

OPTION

EDITION: FIRE SAFE API 607
 TEMPERATURE: -50°C TO 250°C (WITH STEM EXTENSION)
 -40°C TO 280°C (PEEK)
 CONNECTION: NPT, SCH. 40, ANSI B 16.11, EN 12760
 SEAT/PACKING: PEEK, RPTFE, 50%SS/TFM1600, KALREZ® O-RING
 APPROVALS: *FDA (TFM1600/PTFE+GF) STAINLESS STEEL
 VERSION
 BALL SURFACE HARDENING: 1200HV +/-100HV

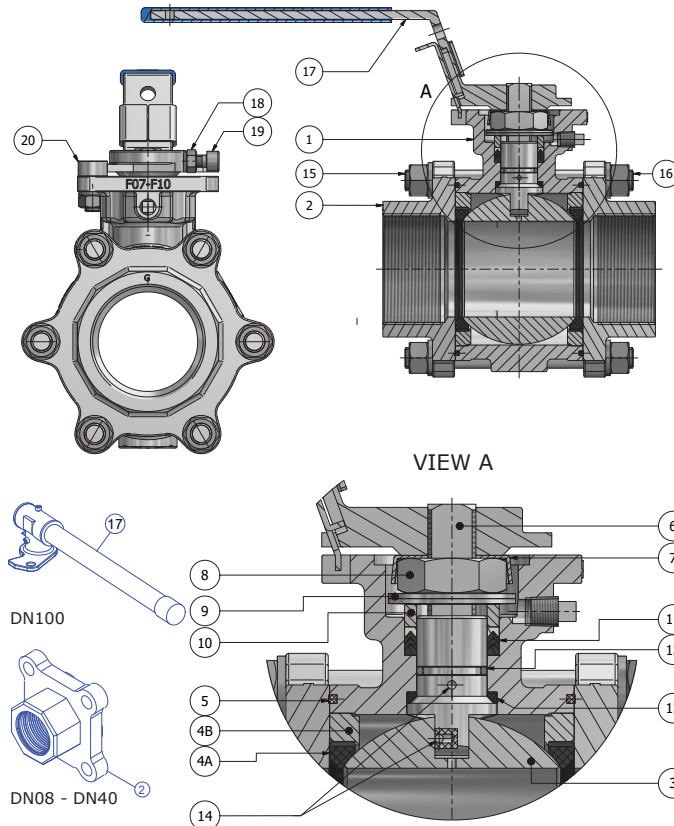

POS	DESCRIPTION	MATERIAL
1	BODY*	STAINLESS STEEL CF8M
2	CONNECTION *	STAINLESS STEEL CF3M/CF8M (THREAD)
3	BALL**	STAINLESS STEEL CF8M
4A	SEAT PACKING	PTFE WITH 25% CARBON (TF 4215)
4B	SEAT HOLDER	AISI 316
5	BODY SEAL RING	PTFE WITH 20% GLASS + 5% CARBON
6	STEM	STAINLESS STEEL AISI 316
7	LOCK NUT CAP	STAINLESS STEEL AISI 304
8	HEX JAM NUT	STAINLESS STEEL AISI 304
9	DISC SPRING	STAINLESS STEEL AISI 301
10	GLAND	STAINLESS STEEL AISI 304
11	STEM PACKING	PTFE WITH 15% GRAPHITE
12	O-RING	VITON 70 GLT
13	CONIC PACKING RING	PTFE WITH 25% CARBON
14	ANTI-STATIC DEVICE	STAINLESS STEEL AISI 316
15	STUD	STAINLESS STEEL AISI 304
16	HEX NUT	STAINLESS STEEL AISI 304
17	HANDLE	STAINLESS STEEL CF8
18	HEX NUT	STAINLESS STEEL AISI 304
19	CYL HEAD CAP SCREW	STAINLESS STEEL AISI 304
20	STOP BOLT	STAINLESS STEEL AISI 304

≥DN65FB includes backup for seat ring in stainless steel

* Type 1251 = A216 Gr. WCB

** DN8 - DN50 = AISI 316

DESCRIPTION

- **Solid ball valve for high performance tasks.** All ball valves are pressure tested and can on demand be delivered with material certificate EN10204/3.1. Available as reduced or full bore.
- **Bolt circle diameter and face to face dimensions** of the body is equal to DVC Type 1210, 1310 (from DN15FB), 1211 and 1311 in all sizes, Worcester and Mecafrance from DN15FB/20RB to DN50FF/65RB. This means that Type 1251/1351 can be mounted between existing end caps.
- **PTFE with 25% carbon** is used for seats and pyramid segment. This material is suitable for high pressure and temperature and is more resistant to wear than traditional PTFE.
- **Stainless steel butt weld end caps acc. to ISO 1127** standard prolonged to be suitable for orbital welding. From stock we can also deliver butt weld end caps acc. to SMS 3008 and BSPP thread ends.
- **Antistatic stem with dynamic stuffing box.** This means a larger contact area together with reinforced stem seat and a surface quality of Ra 0.2 ~ 0.3 um. These advantages provides a very long lifetime.
- **Maintenance free stuffing box** with belleville washers, reinforced V-rings and Viton O-ring provide optimum packing and longer lifetime - also at varying temperatures.
- **ISO 5211 top flange** for direct mounting of actuator without the use of bracket and coupling. Can also be fitted with stem extension.
- **Increased surface hardness of the ball** can be opted for extremely abrasive media to be more resistant to wear and thus extend the lifespan of the ball.
- **Approvals:** ISO 15848-1 emission test, TA-Luft, ATEX, EU1935 on stainless steel version, SIL2, Salt spray tested acc. to ISO 9227. Option: FDA

IDS-1251/1351-UK-06-2024-REV. G
We reserve the right for changes.

DIMENSIONS

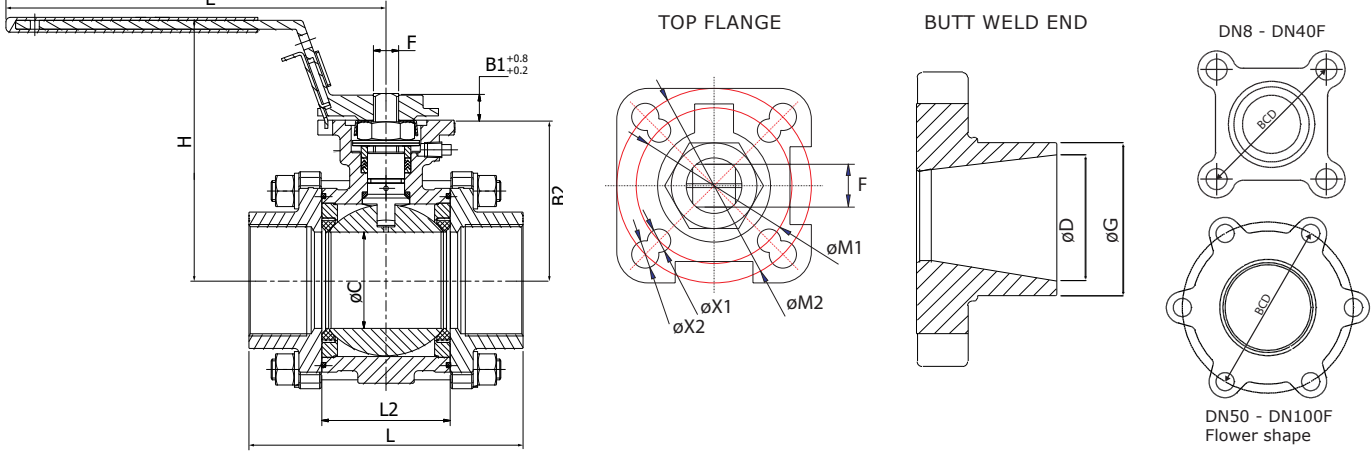

DIMENSION [MM]	VALVE WITH HANDLE									ISO TOP FLANGE				STEM		
	THREAD	L [MM]		L2	B2	ØC	E	H	BCD	ISO 5211	ØM1 [MM]	ØM2 [MM]	ØX1X4 [MM]	ØX2X4 [MM]	F [MM]	B1 [MM]
		1351 BW/SMS	1251 BW													
DN08FB	71.0	116.0	70.6	25.2	40.0	15.0	140.0	83.0	54.0	F03/F04	36	42	5.5	5.5	9.0	9.0
DN10FB	71.0	116.0	70.6	25.2	40.0	15.0	140.0	83.0	54.0	F03/F04	36	42	5.5	5.5	9.0	9.0
DN15FB/DN20RB	72.0	116.0	71.6	25.2	40.0	15.0	140.0	83.0	54.0	F03/F04	36	42	5.5	5.5	9.0	9.0
DN20FB/DN25RB	97.0	125.0	96.6	32.3	45.0	20.0	140.0	88.0	62.5	F03/F04	36	42	5.5	5.5	9.0	9.0
DN25FB/DN32RB	110.0	135.0	109.0	42.3	52.0	25.0	165.0	97.0	71.0	F04/F05	42	50	5.5	7.0	11.0	11.0
DN32FB/DN40RB	118.0	146.0	118.0	49.4	57.0	31.8	165.0	103.0	80.9	F04/F05	42	50	5.5	7.0	11.0	11.0
DN40FB/DN50RB	130.0	157.0/167.0	129.0	57.2	75.0	38.0	202.0	130.0	94.2	F07	-	70	-	9.0	14.0	14.0
DN50FB/DN65RB	142.0	202.0	145.0	71.4	84.0	50.0	202.0	139.0	114.0	F07	-	70	-	9.0	14.0	15.0
DN65FB/DN80RB	185.0	215.0	185.0	86.6	108.0	65.0	257.0	177.0	139.0	F07/F10	70	102	9.0	11.0	17.0	18.0
DN80FB/DN100RB	205.0	230.0	205.0	99.0	118.0	76.0	257.0	187.0	160.0	F07/F10	70	102	9.0	11.0	17.0	18.0
DN100FB	240.0	260.0	241.0	127.0	140.0	100	405.0	207.5	193.0	F10	102	-	11.0	-	22.0	22.5

VALVE DATA

DIM		TORQUE*		WEIGHT		KV-VALUE		PRESSURE AND BUTT WELD ENDS [R=REDUCE BORE] [F=FULL BORE]								
[MM]	[INCH]	FB [NM]	RB [NM]	FB [KG]	RB [KG]	90° m³/h		TYPE 1251			TYPE 1351			TYPE 1351		
						FB	RB	EN 12627			ISO 1127			SMS3008		
								ØG/ØD (MM)			ØG/ØD (MM)			ØG/ØD (MM)		
DN08	1/4"	9	-	0,9	-	8,0	-	14/11,5 (1,25)	F	PN102	13,5/10,3 (1,6)	F	PN99	-	-	-
DN10	3/8"	9	-	0,9	-	9,0	-	17,2/12,6 (2,3)	F	PN102	17,2/14,0 (1,6)	F	PN99	12,0/10,0 (1,0)	PN99	F
DN15	1/2"	9	9	1,0	0,8	11,0	9,0	21,7/15 (3,35)	R/F	PN102	21,3/18,1 (1,6)	R/F	PN99	18,0/16,0 (1,0)	PN99	F
DN20	3/4"	12	9	1,5	1,0	28,0	11,0	27,2/20,5 (3,35)	R/F	PN102	26,9/23,7 (1,6)	R/F	PN99	25,0/22,6 (1,2)	PN99	R/F
DN25	1"	20	12	2,0	1,5	48,0	28,0	34/25,7 (4,15)	R/F	PN102	33,7/29,7 (2,0)	R/F	PN99	32,0/29,6 (1,2)	PN99	R
DN32	1 1/4"	33	20	3,0	2,0	71,0	48,0	42,7/34,4 (4,15)	R/F	PN102/80	42,4/38,4 (2,0)	R/F	PN99/80	33,7/31,3 (1,2)	PN99	R
DN40	1 1/2"	40	33	4,5	3,0	104,0	71,0	48,6/40,3 (4,15)	R/F	PN80	48,3/44,3 (2,0)	R/F	PN80	38,0/35,6 (1,2)	PN74	R
DN50	2"	66	40	6,5	4,5	208,0	104,0	60,5/51,3 (4,6)	R/F	PN80/76	60,3/55,1 (2,6)	R/F	PN80/76	51,0/48,6 (1,2)	PN56	R
DN65	2 1/2"	112	66	12,5	6,5	277,0	208,0	76,3/67,1 (4,6)	R/F	PN76/69	76,1/70,9 (2,6)	R/F	PN76/69	63,5/60,3 (1,6)	PN59	R
DN80	3"	113	112	16,5	12,5	502,0	277,0	88,9/80 (4,45)	R/F	PN69/51	88,9/83,7 (2,6)	R/F	PN69/49	76,1/72,9 (1,6)	PN49	R
DN100	4"	156	113	26,0	16,5	882,0	502,0	116/103,1 (6,45)	R/F	PN51	114,3/109,1 (2,6)	R/F	PN49	101,6/97,6 (2,0)	PN46	R

* Torque figures include 30% safety factor. (TEST: 0 bar diff. pressure, ambient temperature, non-lubricating).

PRESSURE/TEMPERATURE

