

Model 1216

DESCRIPTION

Safety and relief valve, angle type, conventional
 Direct spring loaded
 Full lift safety valve
 Stainless steel, DUPLEX (on request)
 Steam, gases, cryogenic fluids, vapours and liquids
 Cleaned and degreased for oxygen service
 Threaded BSP / NPT
 PN 40
 Seat metal- metal, Viton and PTFE
 Set pressure range 0,2 to 40 barg
 Tolerance Set pressure $\pm 3\%$
 Overpressure 10%
 European Pressure Equipment Directive PED 2014/68/EU
 CE 0056 Module B
 CE Production Quality Assurance (Module D) ES037955- 1035
 Material test certificate EN 10204 3.1

TOSACA, MADE IN SPAIN



MATERIALS

Item	Components	Material	Cryogenic
1	Nozzle	A351 CF-3M	A351 CF-3M
2	Body	A351 CF-3M	A351 CF-3M
4	Cap	A351 CF-8	A351 CF-8
5 ^{SP}	Disc	AISI-316L	AISI-316L
6	Guide	A351 CF-3M	A351 CF-3M
7	Push Rod	AISI-316L	AISI-316L
8	Spring Button	AISI-303	AISI-303
9	Ajusting Screw	AISI-303	AISI-303
10	Tensor Nut	AISI-303	AISI-303
11 ^{SP}	Spring	AISI-302	INCONEL X 750
12	Lever	A351 CF-8	A351 CF-8
17	Release nut	AISI-304	AISI-304
18 ^{SP}	Lever axis	AISI-303	AISI-303
19	Packing lever axis	AISI-303	AISI-303
20 ^{SP}	Gasket cap	PTFE	PTFE
21 ^{SP}	Gasket	PTFE	PTFE
22 ^{SP}	Gasket pack. lever	Viton	Viton
28 ^{SP}	Soft seat	Viton / PTFE	Metal

^{SP} Recommended spare parts

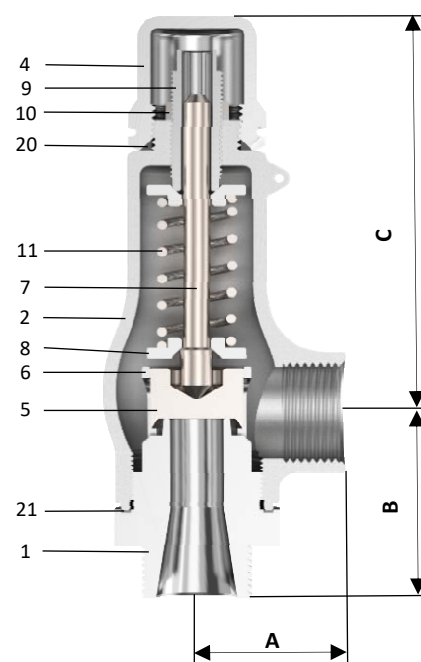

DIMENSIONS

	Orifice (mm)	Area (mm ²)	A (mm)	B (mm)	C (mm)	Weight (kg)
1/2" x 3/4"	13	133	45	57	155	2,2
1/2" x 1"	13	133	45	57	155	2,2
3/4" x 1"	14	154	45	57	155	2,2
1" x 1"	16	201	45	60	155	2,2
1" x 1 1/4"	16	201	45	61	155	2,3
1" x 2"	22	380	62	87	234	4,5
1 1/4" x 1 1/4"	18	254	45	62	155	2,4
1 1/2" x 2"	28	616	62	89	234	4,6
2" x 2"	32	804	62	93	234	5,1

Version 2023

www.tosaca-valves.com